

A c c e s s o r i e s f o r I n s t r u m e n t s

TURBIDITY sensor

ETORB

A.T.A. turbidity sensors are the ideal complements to A.T.A. controllers for an accurate and reliable control of your processes.

Turbidity easy-maintenance sensors provide accurate reading values and fast responses, performances required for the most accurate measurements.

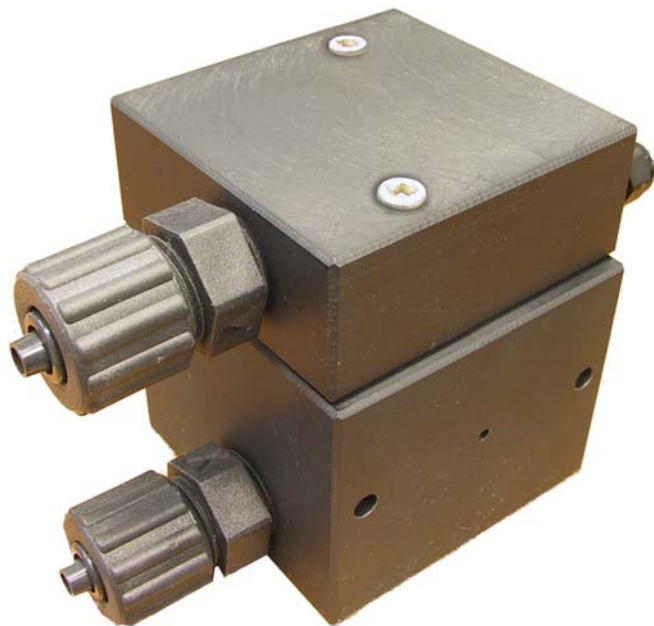

ETORB

Off line turbidity sensor. Measurement range 0 ÷ 40 NTU. Max flow 40l/h, 0,5 bar.

HOW DOES IT WORK

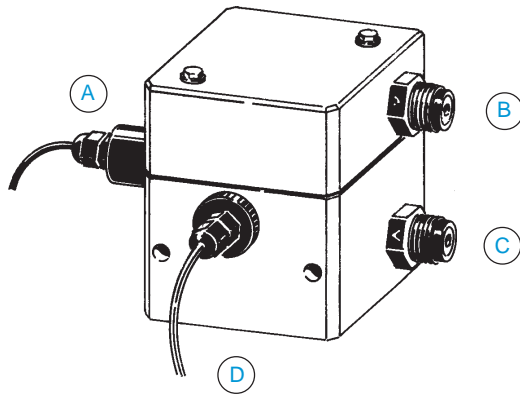

- A Emitter Photodiode
- B Sampled liquid output
- C Sampled liquid input
- D Receiver Photodiode

Turbidity is defined as an “expression of optical property that causes light to be scattered and absorbed rather than transmitted in straight lines through the sample.” Simply stated, turbidity is the measure of relative sample clarity. High turbidity makes it difficult to treat water for microbial contaminants, and therefore is regulated in drinking water supplies by the EPA. The turbidimeter measures the light transmittance of a sample in NTU’s (Nephelometric Turbidity Units, a standard measure). Because the units of turbidity are quite arbitrary, it’s absolutely essential that turbidimeters be calibrated against standards with known scattering properties. Basically, these are solutions of very special substances that scatter light in a predictable and repeatable fashion.

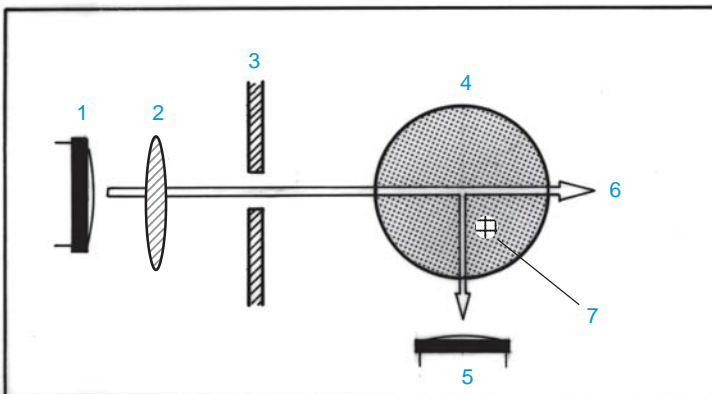
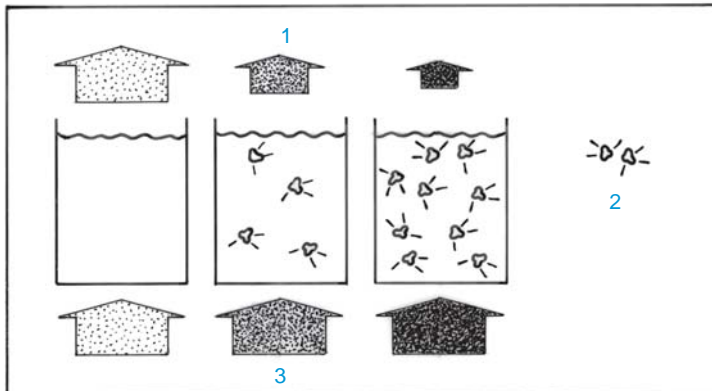

JATA S.r.l.
 Via Molinello 38 16035 Rapallo (GE)
 Tel. +39 0185263015 Fax +39 0185260114
 Http://www.atasrl.it e-mal:atasrl@atasrl.it
 P.iva 03588120109

**sistemi di dosaggio
 trattamento acque
 fertirrigazione
 automazione**