

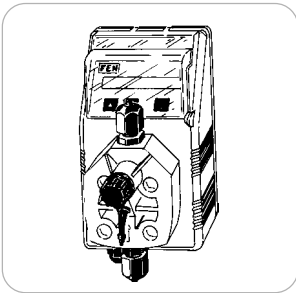

This operating instructions contains safety information that if ignored can endanger life or result in serious injury. They are indicated by this icon.



Use of this pump with radioactive chemicals is forbidden!



## OPERATING INSTRUCTIONS MANUAL FOR “FMS DIGITAL” PUMPS



Keep the pump protected from sun and water.  
Avoid water splashes.

Please read it carefully!



English language



“FMS Digital” series solenoid dosing pumps comply with the following European regulations:

EN60335-1 : 1995, EN55014, EN50081-1/2, EN50082-1/2, EN6055-2, EN60555,3

Based on directive CEE 73/23 c 93/68 (DBT Low voltage directive) and directive 89/336/CEE (EMC Electromagnetic Compatibility)



All metering pumps with 230 VAC and 115 VAC power supply with FP o-rings are listed NSF 50 (except for 03 6,5, 03 8,5).



All metering pumps supplied with 115 VAC are available with certification CSA.



## GENERAL SAFETY GUIDELINES

### Danger!

In emergencies the pump should be switched off immediately! Disconnect the power cable from the power supply!

When using pumps with aggressive chemicals observe the regulations concerning the transport and storage of aggressive fluids!

When installing outside European Community, always observe national regulations!

Manufacturer is not liable for any unauthorized use or misuse of this product that can cause injury or damage to persons or materials!

### Caution!

Pumps must be accessible at all times for both operating and servicing. Access must not be obstructed in any way!

Feeder should be interlocked with a no-flow protection device to automatically shut-off the pump when there is no flow!

Pumps and accessories must be serviced and repaired by qualified and authorized personnel only!

Always discharge the liquid end before servicing the pump!

Empty and rinse the liquid end before work on a pump which has been used with hazardous or unknown chemicals!

Always read chemical safety datasheet!

Always wear protective clothing when handling hazardous or unknown chemicals!

# INDEX

Design and function .....	4
Illustrated views of “fms” pump .....	5
Panels views of “fms” pump .....	6
Electronic boards connections .....	7
Pump’s package .....	8
Electrical installation .....	9
Basic operations .....	11
Programming “fms ext” pump .....	12
Programming “fms ph” pump .....	14
Password .....	16
Maximum time dosing alarm .....	16
Programming “fms rh” pump .....	17
Password .....	18
Maximum time dosing alarm .....	18
Programming “fms en” pump .....	20
Troubleshooting .....	23
Pump’s messages .....	23
O-rings, maintenance and repair operations .....	24
Technical features and manufacturing materials .....	25
Exploded view .....	26
Dimensions .....	27
Setup diagram for fms solenoid metering pumps .....	28
Recommended chemicals table .....	31
Delivery curves .....	32
Auto-venting pump head .....	34

---

## Design and Function

---

**"FMS Digital" series magnetic membrane batching pumps are ideal for small and medium dosing of liquid products.**

*Main Components:* Casing (PP+Fiber Glass, IP65 rating)  
PCB (Printed Circuit Board)  
Solenoid with stroke adjustment  
Diaphragm (PTFE)  
Pump Head (PP)

*Pump Capacity:* Flow rate is determined by the stroke rate. Repeatability is ensure within range between 30% and 100%.

*Operating Modes:* The pump working mode is intermittent: a magnetic field is created each time a pulse reaches the magnet. The magnetic field pushes the piston. A diaphragm (fixed on the piston head) compresses the liquid into the pump head. The liquid gets out through the delivery valves while the suction valves close. When the pulse ends, a spring takes back the piston and the diaphragm. The vacuum created by the diaphragm movement takes the liquid inside the pump head from the suction valve, while the delivery valve is closed. The pump capacity is proportional to the number of strokes and to the pump head internal volume (Single Stroke Injection Quantity).

*Models available*

### **FMS PH**

Proportional pump driven by internal built-in pH meter (0÷14 pH) and level control. pH electrode input (electrode not included).

### **FMS RH**

Proportional pump driven by internal built-in Redox (ORP) meter (0÷1000mV) and level control. Redox electrode input (electrode not included).

### **FMS EN**

Pump with weekly timer, microprocessor, digital controls, LCD display, level control and electrovalve.

### **FMS EXT**

Multifunction-Proportional pump with analogic/digital signal input, level control, display and microprocessor.

## Illustrated views of “FMS” pump

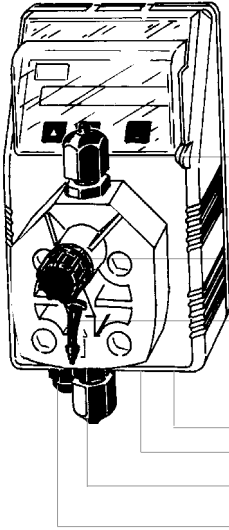

Discharge connection

De-gassing knob

De-gassing outlet

pH or Rh / External control output  
Level probe input signal

Suction connector

Power supply cable

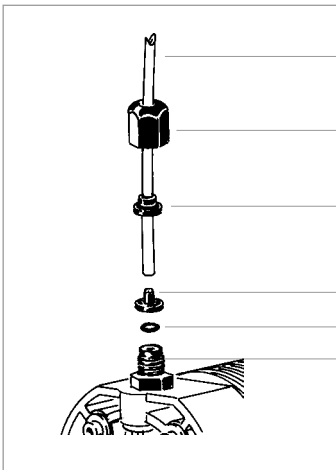

Discharge hose (PE Hard)

Hose nut

Clamping ring

Nozzle

O-ring

Discharge valve connection

## Panels views of "FMS" pump

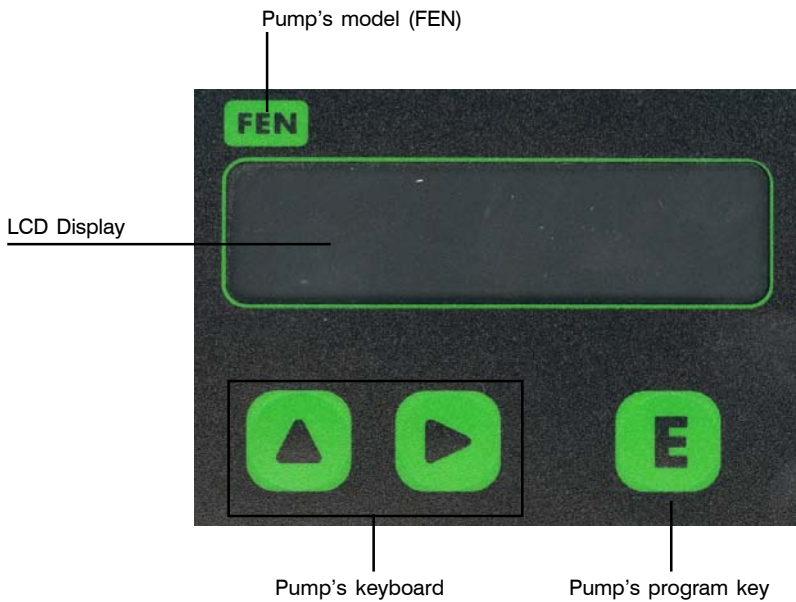
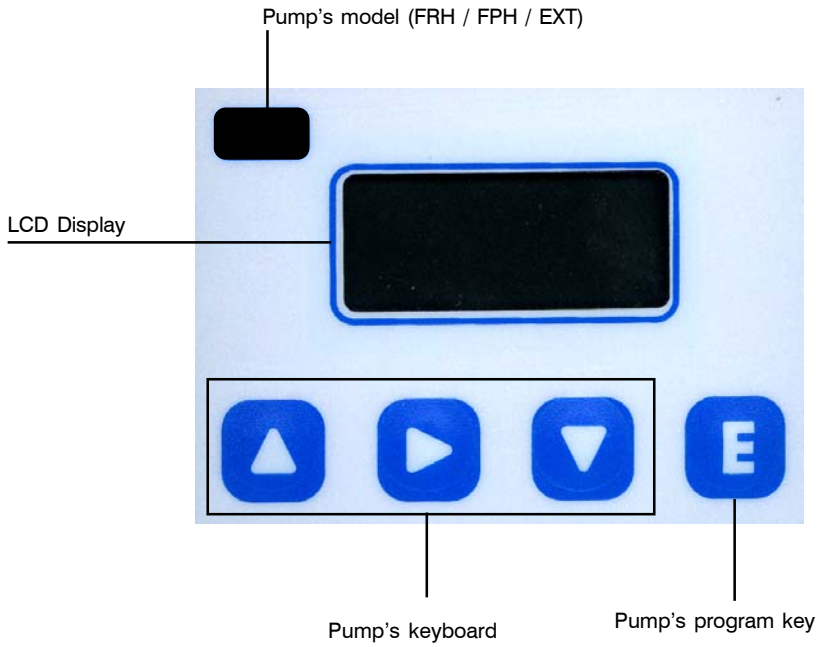

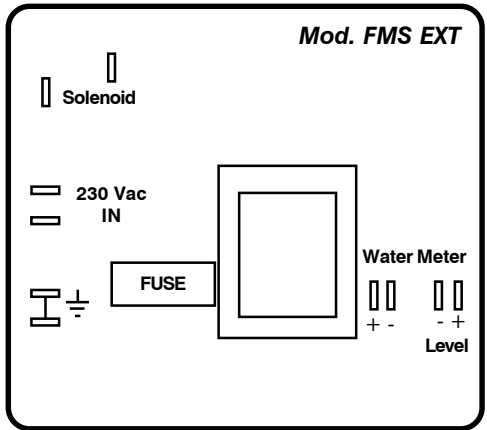
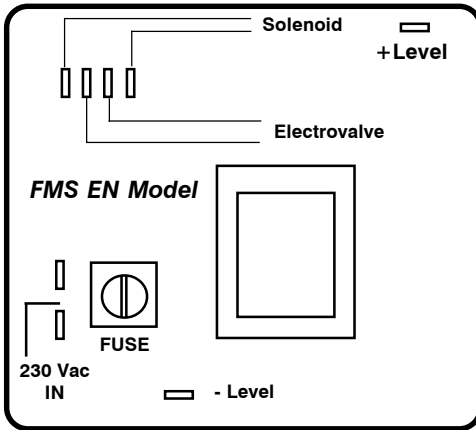
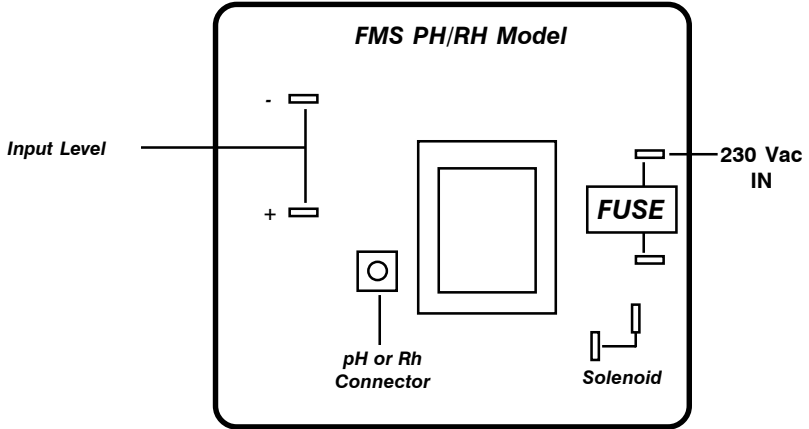

**All Models:**  
Connect ground cables with power supply ground cable using the included clip.

**220Vac Output:**  
Not available for "FMS PH" and "FMS RH" models.

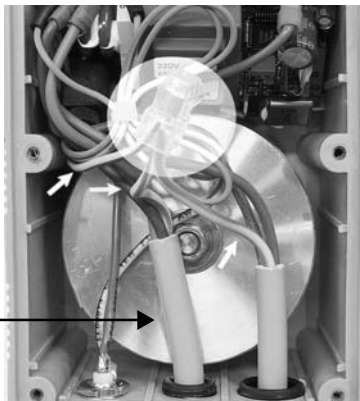

## Pump's package

---

Included into package:

n.2	Dibbles ø6
n.4	Screws 4,5 x 40
n.1	Delayed fuse 5 X 20
n.1	Foot filter with valve
n.1	Injection valve
n.1	Level probe
m 2	Delivery pipe
m 2	Suction pipe
m 2	Discharge pipe
n.1	This operating instructions manual



**PLEASE DO NOT TRASH PACKAGING.  
IT CAN BE USED TO RETURN THE PUMP.**

Commissioning the pump:

Make sure that the pump is fastened into place firmly and will not vibrate during use!



Ensure that the pump is accessible at all times for operating and maintenance purposes!

Suction and discharge valves must be in vertical position!

The metering pump must be installed with the pump's basement on horizontal position!

Assembly and install hoses:

The suction hose (PVC flexible) should be short and placed vertical to avoid air bubble collecting!

Calculate cross section and length to ensure that negative pressure in the suction hose does not reach the vapour pressure for chemical's feed!

**FREE END OF SUCTION HOSE SHOULD BE INSERTED  
JUST ABOVE THE BASE OF NOZZLE!**



**USE ONLY HOSES COMPATIBLES WITH PRODUCT TO DOSE.  
PLEASE REFERS TO "CHEMICAL COMPATIBILITY TABLE" OF  
PRODUCT TO DOSE!**

Pump has to be connected to power supply using the standard "SCHUKO" plug supplied or the special power supply cable.



**Before starting any electrical connection perform the following operations:**

- ensure a correct ground installation!
- if there is a bad ground, install a differential switch with high sensibility (0,03 A) as additional protection from electric shocks!
- check that pump voltage corresponds to supply voltage!
- make ground connection before any other connection!

Electrical features:

Power supply range for 230 V model: 184÷270 VAC

Power supply range for 115 V model: 92÷136 VAC

If pump is powered with out of range mains value, the display will show "OUT OF RANGE" or power led will blink (model without display).

Average power consumption and fuse replacement:

<i>Model Pump</i>	<i>Consumption at 230 Vac and Fuse Value</i>	<i>Consumption at 115 Vac and Fuse Value</i>
FMS-xxx 12 1,5	230 VAC / 630mA 16W	115 VAC / 315mA 11W
FMS-xxx 10 2,2	230 VAC / 630mA 16W	115 VAC / 315mA 11W
FMS-xxx 07 03	230 VAC / 630mA 16W	115 VAC / 315mA 11W
FMS-xxx 07 05	230 VAC / 800mA 16W	115 VAC / 500mA 13W
FMS-xxx 05 05	230 VAC / 630mA 16W	115 VAC / 315mA 11W
FMS-xxx 06 06	230 VAC / 800mA 16W	115 VAC / 500mA 13W
FMS-xxx 05 07	230 VAC / 800mA 16W	115 VAC / 500mA 13W
FMS-xxx 01 07	230 VAC / 630mA 16W	115 VAC / 315mA 11W
FMS-xxx 01 09	230 VAC / 800mA 16W	115 VAC / 500mA 13W
FMS-xxx 03 6,5	230 VAC / 630 mA 16W	
FMS-xxx 03 8,5	230 VAC / 800 mA 16W	

## Electrical Installation

### REPAIRS MUST BE PERFORMED BY AUTHORIZED PERSONNEL ONLY



**Do not connect the pump in parallel to an inductance load, e.g. motors, to prevent electronic circuitry damages. Always use a connector to cut off spikes due to other devices switching.**

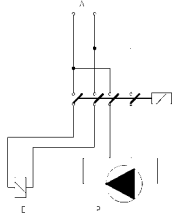
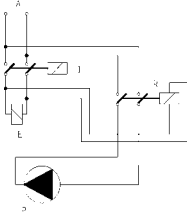

*P - Dosing Pump  
R - Relay  
I - Switch or device with many safety poles  
E - Electrovalve or inductive load in general  
A - Supply voltage*

Internal circuitry is protected against noises using the EMC system and with a fuse located under the front cover of pump. To replace the fuse (**trained personnel only**) do as follow:

- Unplug power supply
- Remove the 6 screws placed on the back side with a cross-head screwdriver
- Remove the frontal cover
- Locate fuse on main board and replace it (5x20 T slow blow) use only approved fuses reported in the table here below

FMS Digital pump is equipped with an overvoltage protection (300V, 150V) and a voltage peak protection up to 4KV, 50 $\mu$ sec against pulses as shown in fig. 1.

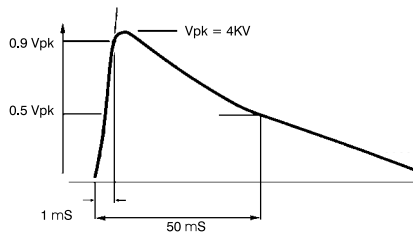

fig. 1

### PRIMING

To prime the pump without touching chemicals please performs these operations:

- connect all hoses into proper places (delivery hose, suction hose and outgassing hose).
- open outgassing valve and turn on the pump.
- set pump's single injection at 100% and pulses at 50%.

All air inside the pump head will exit through the outgassing outlet. When product will leak from it, close immediately the outgassing valve. If dosing product is particularly dense, to facilitate the priming, insert on vent pipe a syringe of 20 cc and suck inside.

### DOSING

Pump's technical features are printed on a label located on pump's box: model, supply voltage, working counterpressure (Kpa/bar) and pump capacity (l/h). All these dosing information are calculated by dosing water at 20 °C temperature, at the maximum counterpressure reported on the label, using the injection valve and the % knob set to maximum. Dosing accuracy is  $\pm 2\%$  l/h at constant maximum counterpressure and 1 cps flow (**max viscosity: 60 cps**).



**Caution: injection capacity is a constant value but a variation in counterpressure or product's viscosity may cause some changes. For further details see "delivery curves" paragraph.**

**For recommended chemicals for swimming pools and SPAs, see page 32.**

### LEVEL PROBE AND FOOT FILTER INSTALLATION

Level probe must be assembled using the foot valve included into pump's kit. Foot valve is designed to be installed in contact with tank base. It is not necessary a space to avoid sediment accumulation. Connect the BNC to dosing pump using "LEVEL" input.

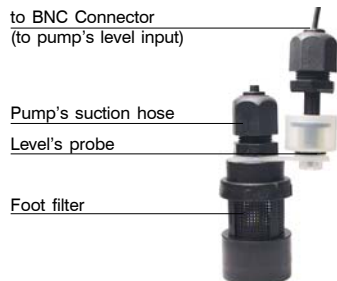
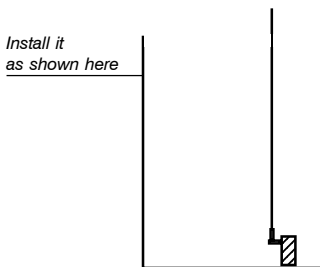

---

## Programming the “FSM” EXT” pump

---

All dosing pumps are equipped with a keyboard that basically works in the same way for any pump’s model. To avoid any misunderstanding during this chapter all keys will be described as shown on this legend:



is the “UP”, “ON/OFF” key



is the “DOWN”, “SCROLL” key



is the “RIGHT”, “ESC” key



is the “E” key

### PROGRAMMING “FMS EXT” PUMP

#### Entering in program mode

Press “E” key. Pump’s display shows “PASSWORD 000000”. Use “UP” (to increase units) and “E” (to change digit) keys to edit the proper code. Press “E” to confirm. Default password is “000000”. In this case, just press “E” to confirm.

#### Programming mode functions

Use “UP” (scroll up) and “DOWN” keys (scroll down) to see all the options. With “ESC” keys, it is always possible to exit from programming mode. Options are:

- 1) mA
- 2) Volt
- 3) Div
- 4) Mult
- 5) Const
- 6) M/pls
- 7) H/pls
- 8) Pword
- 9) Sefl

To modify parameters press “E”, select the option and press “E”. Use “UP” and “DOWN” to increase units “ESC” to scroll on the next function. To save and exit press “E”, press “DOWN” to change “Save NO” in “Save YES”. Press “E” to go back to programming menu. Then press “ESC” to go back to functioning mode. The display shows “CONSTANT STAND-BY” for 10 seconds.

**NOTE: The pump goes back to the main programming menu without confirming the saving with a message.**

#### 1) mA

a) 0%  
4.0 mA

b) 100%  
20.0 mA

Set these parameters for proportional functioning mode in the values between 3.9mA and 20.0mA.

When the pump reaches 20.0mA, it will work at 100% of its capacity. When the pump reaches 4.0, it will stop dosing. Between these values it will work proportionally.

### **2) Volt**

As mA. Set these parameters for proportional functioning mode in the values between 0 and 9.9Volts. When the pump reaches 9.9Volts, it will work at 100% of its capacity. When the pump reaches 0Volts, it will stop dosing. Between these values it will work proportionally.

### **3) Div**

Input pulse divider from 1 to 999.

### **4) Mult**

Input pulse multiplier from 1 to 999.

### **5) Const**

Constant functioning mode (without input pulses). The pump gives the setted pulses constantly from 0% (0 pulses per minute) to 100% (150 pulses per minute).

### **6) M/pls**

Constant dosing mode. It is possible to set pulses/minute from 1 to 120 (e.g.: 120 minutes per each pulse).

### **7) H/pls**

Constant dosing mode. It is possible to set pulses/hour from 1 to 3 (e.g.: 3 hours per each pulse).

### **8) Pword**

Use this menu to set your own password.

### **9) Sefl (Proximity Sensor)**

Use this function if a SEFL is connected to the pump. It is possible to set pulses from 1 to 50 or disable it (default: off). Move cursor on "NO DOS" and change it to "DOSING" to continue dosing even if a proximity error occurs. Leave it on "NO DOS" to stop dosing if a proximity error occurs within the selected pulses.

To reset the pump: unplug power supply, press both "UP", "RIGHT" and "DOWN" keys. Keeping pressed these keys, plug power supply. Leave the keys and then press "E" to confirm.

---

## Programming the “FMS PH” pump

---

### PROGRAMMING “FMS PH” PUMP

#### Entering in program mode

Turn on the pump. Keep pressed “E” key for at least 4 seconds to enter in program mode. Pump’s display shows:

**PASSWORD:**

→ 0000 fig.1

Use “UP” and “DOWN” keys to edit the password, press “RIGHT” to move on next digit.

#### “SETUP” program

Once entered the password, pump’s display shows:

→ SETUP  
PARAM fig.2

Move arrow on SETUP then press “E” key:

#### “SET POINT” program

**Setup**

1) Point fig.3

Press “E” key:

a) → 00%  
7.30pH fig.4

The display shows that pump does not work at 00% if pH is 7.30. Make sure that arrow is on “7.30 pH” to change this value, then use “UP” and “DOWN” keys to enter a new value. Use “RIGHT” key to move on next value. Once on “00%”, change it with “UP” and “DOWN” keys. It’s possible to choose “OFF” instead of a number for “On/Off” working mode.

b) → 100%  
7.80pH fig.5

The display shows that pump works when pH is 7.80. Make sure that arrow is on “7.80pH” to change this value, then use “UP” and “DOWN” keys to enter a new value. Use “RIGHT” to move on next value. Once on “100%”, change it with “UP” and “DOWN” keys. Press “E” key to confirm values and quit from programming mode. Display shows for a few seconds: DATA SAVED. To exit from program mode press “RIGHT” key twice. Now the pump will modify proportionally its own dosing capacity in the range between 7.30pH and 7.80pH. On previous example, dosing mode is for “acid”. It’s possible to choose “ON” for “On/Off” working mode.

### Probe calibration

To obtain a reliable measurement it is necessary (during installation) calibrate the probe. To do this, two buffer solutions are needed: a 7.00pH buffer solution and a 4.00pH or 9.00pH buffer solution. Proceed as follows:

- 1) Measure buffer solution temperature and verify if it is the same printed on solution's label.
- 2) Insert probe's connector (blue colour) into pump's input connector.
- 3) Remove protective cap from probe and wash it into water. Then dry it.

Into "Setup" menu (fig.3), choose "2)Calib" then press "E" key. The display shows:

**R: 7.20 pH**  
**C: 7.00 pH**

**fig.6**

"R" means buffer solution reading value and "C" the calibration to refer to. During the calibration the "R" value could be different from the buffer solution value. Wait a stable reading in "R". Dip probe in a 7.00 pH buffer solution and use "UP" and "DOWN" keys to change the value in "C:" to have buffer solution value. Wait a stable reading in "R:" then press "E" key to confirm this first calibration. Pump will show:

**R: 7.00 pH**  
**C: 4.00 pH**

**fig.7**

Remove the probe from first buffer solution and repeat the cleaning procedure. Then dip probe into second buffer solution (for example 4.00 pH) and use "UP" and "DOWN" keys to change the value in "C:" to have buffer solution value. Wait a stable reading in "R:" then press "E" key to confirm. The pump will show the new values for a while and will return to main menu.

**59mV / pH**  
**- 000 mV**

**fig.8**

If calibration process fails the pump will show "PH CALIB FAILED". Not changing any value the program will return to "Calib" mode. To exit press "RIGHT" key twice.

### DELAY

In main menu choose "PARAM" (fig.2) and press "E" key. Display shows:

**DEL.: ->00**  
**0 0 0 0**

**fig.9**

The -> arrow is on "DEL". *This value is pump's waiting time after any start up procedure*: pump will wait set time before start dosing every time it is powered on. Use "UP" and "DOWN" keys to change this value. Waiting time may be set from 1 to 60 minutes.

---

## Programming the pump

---

### PASSWORD

In main menu choose "PARAM" (fig.2) and press "E" key. Display shows:

**DEL: →00**

**0 0 0 0**

**fig.9**

Press "RIGHT" key to move on 0 0 0 0. All new pumps have "0 0 0 0" as default password, use "UP" and "DOWN" keys to change this value. Press "E" to confirm new data. The pump shows the new password for about two seconds then it'll return to main menu. Press "RIGHT" key to leave main menu.

### MAXIMUM TIME DOSING ALARM

This alarm prevents the pump to dose if a set time is reached. To set this alarm enter into "Setup menu" as shown in fig.3. Use "DOWN" key to choose "3) Alarm" and press "E" key. The pump shows:

**-> AL OFF**

**DOSING**

**fig.10**

To activate the alarm use "UP" or "DOWN" keys to set the time (from 1 to 100 minutes or "AL OFF"). To setup the alarm mode use the "RIGHT" key. Cursor moves on "DOSING". Use "UP" or "DOWN" keys to change this voice. On "STOP" mode the pump will stop the dosing procedure once the set time is reached. The pump's display will show the alarm condition and requires to press a key to continue. On "DOSING" mode the pump will NOT stop the dosing procedure once the set time is reached. The pump's display will show the alarm condition and requires to press a key to continue.

### Special functions

- Keep pressed the "UP" key to turn off the pump. Display shows "OFF" and it will switch off. Keeping pressed the "UP" key the pump will switch on.
- Keep pressed the "DOWN" key to read on display the power supply input.
- Keep pressed the "E" key for manual dosing.
- Pump's reset: turn off the pump, keep pressed "UP" and "DOWN" keys then turn on the pump. Release "UP" and "DOWN" keys and proceed to pump's set-up. This procedure will return the pump to its shipment condition.

### PROGRAMMING “FMS RH” PUMP

Turn on the pump. Keep pressed “E” key for at least 4 seconds to enter in program mode. Pump's display shows:

**PASSWORD :**

→ 0000 fig.1

Use “UP” and “DOWN” keys to edit the password, press “RIGHT” to move on next digit.

#### “SETUP” program

Once entered the password, pump's display shows:

→SETUP  
PARAM fig.2

Move arrow on “SETUP” then press the “E” key:

#### “SET POINT” program

**Setup**

1) Point fig.3

Press “E”, the display will show:

a) →100%  
650mV fig.4

The pump works at 100% of its capacity if ORP value is 650mV. Make sure that arrow is on “650mV” to change it and then use “UP” and “DOWN” keys to enter a new value. Use “RIGHT” key to move on next digit. Move arrow on 100% and change using the “UP” and “DOWN” keys.

b) →00%  
700mV fig.5

The display shows that pump stops when ORP is 700mV. Make sure that arrow is on 700mV to change this value then use “UP” and “DOWN” keys to enter a new value. Use “RIGHT” key to move on next digit. Move arrow on 100% and change using the “UP” and “DOWN” keys. Press “E” key to confirm values and quit from programming mode. Display shows for a few seconds: DATA SAVED. Pump will change proportionally its dosing capacity between 650mV and 700mV. Now the pump will modify proportionally its own dosing capacity in range between 650mV and 700mV. In previous example pump will dose “chlorine”.

---

## Programming the pump

---

### Probe calibration

To obtain a reliable measurement it is necessary (during installation) calibrate the probe. To do this, a known buffer solutions is needed. Proceed as follows:

- 1) Measure buffer solution temperature and verify if it is the same printed on solution's label.
- 2) Insert probe's connector (blue color) into pump's input connector.
- 3) Remove protective cap from probe and wash it into water. Then dry it.

Into "Setup" menu (fig.3), choose "2)Calib" then press "E" key. The display shows:

**R: 600 mV**

**C: 650 mV**

**fig,6**

"R" means buffer solution reading value and "C" the calibration to refer to. During the calibration the "R" value could be different from the buffer solution value. Wait a stable reading in "R". Dip probe in a 650mV buffer solution and use "UP" and "DOWN" keys to change the value in "C": to have buffer solution value. Wait a stable reading in "R:" then press "E" key to confirm. Display shows probe's data before to return at main menu. If calibration process fails the pump will show "MV CALIB FAILED". Not changing any value the program will return to "Calib" mode. To exit press "RIGHT" key twice.

### DELAY

In main menu choose "PARAM" (fig.2) and press "E" key. Display shows:

**DEL.: ->00**

**0 0 0 0**

**fig.9**

The -> arrow is on "DEL". *This value is pump's waiting time after any start up procedure:* pump will wait set time before start dosing every time it is powered on. Use "UP" and "DOWN" keys to change this value. Waiting time may be set from 1 to 60 minutes.

### PASSWORD

In main menu choose "PARAM" (fig.2) and press "E" key. Display shows:

**DEL.: ->00**

**0 0 0 0**

**fig.9**

Press "RIGHT" key to move on 0 0 0 0. All new pumps have "0 0 0 0" as default password, use "UP" and "DOWN" keys to change this value. Press "E" to confirm new data and "RIGHT" to exit from programming mode.

### MAXIMUM TIME DOSING ALARM

This alarm prevents the pump to dose if a set time is reached. To set this alarm enter into "Setup menu" as shown in fig.3. Use "DOWN" key to choose "3) Alarm" and press "E" key. The pump shows:

### -> AL OFF DOSING

fig.10

To activate the alarm use “UP” or “DOWN” keys to set the time (from 1 to 100 minutes or “AL OFF”). To setup the alarm mode use the “RIGHT” key. Cursor moves on “DOSING”. Use “UP” or “DOWN” keys to change this voice. On “STOP” mode the pump will stop the dosing procedure once the set time is reached. The pump’s display will show the alarm condition and requires to press a key to continue. On “DOSING” mode the pump will NOT stop the dosing procedure once the set time is reached. The pump’s display will show the alarm condition and requires to press a key to continue.

### Special functions

- Keep pressed the “UP” key to turn off the pump. Display shows “OFF” and it will switch off. Keeping pressed the “UP” key, the pump will switch on.
- Keep pressed the “DOWN” key to read on display the power supply input.
- Keep pressed the “E” key for manual dosing.
- Pump’s reset: turn off the pump, keep pressed “UP” and “DOWN” keys then turn on the pump. Release “UP” and “DOWN” keys and proceed to pump’s set up. This procedure will return the pump to its shipment condition.

---

## Programming the “FMS EN” pump

---

### PROGRAMMING “FMS EN” PUMP

“FEN” is a “up to 16 daily programs” timered dosing pump (max 16 weekly programs). During a week (7 days) all the 16 programs may be enabled or disabled each day. Dosing quantity may be set for each program and distributed for a set time.

Keep pressed “**E**” key for at least 4 second. The display shows:

Enter Password  
-> 0 0 0 0

This is the password to enter into pump’s “programming mode”. Press “**RIGHT**” key to scroll through the units and insert proper code. Default code is 0000. To confirm it, press “**E**” key. The display shows:

-> Run Mode  
Clock

Use “**UP**” (scroll up) and “**RIGHT**” keys (scroll down) to see all the options. Options are:

Run Mode  
Clock  
Program  
Injection  
Water  
Password  
Supply Volt.

#### **Clock option:**

The display shows date and time. Use “**UP**” (scroll) and “**RIGHT**” (change field) keys. Date’s format is: DD/MM/YY. To confirm press “**E**” key.

#### **Progr. Option:**

To select “Progr.” press “**E**” key (option is selected when the -> arrow is on it). The display shows:

1: On 8:30  
M T W T F S S

The 1) is the program 1 of 16. This pump can be set for a maximum of 16 daily programs.

0:00 is the starting time.

Arrows on letters are the active dosing days (M-Monday; T-Tuesday; etc). It is possible to scroll it and choose/add another day with “**UP**” key. Off is program’s status.

Example: M T W <T F S S < This example shows enabled programs: Wednesday and Sunday.

Press "RIGHT" key until the display shows:

0100 cc  
001 min

0100 cc is product's quantity to dose.

001 min is the time set by user to perform the dosing procedure. If time is not enough do dose a certain quantity of product, then the pump will extend its dosing activity through the time. Otherwise the pump will delay the dosing capacity until it will matches the set time.

**Important note: Do not set two programs with a common time during the same day. Doing this, pump will not accomplish last edited program.**

### ***Inject option:***

The display shows:

Single Injection  
00,56 cc/imp

This is the quantity of product dosed for each pump's pulse. If needed change this parameter according to the manufacturer or install the pump on plant and perform a pump's suction test on 100 pulses to obtain a reliable result.

### ***Water option:***

The display shows:

Before: -> 04 sec  
After: 05 sec

"Before" (min: 0 seconds; max: 60 minutes); "After" (min: 0 seconds; max: 60 minutes). Pump has a 230Vac output for a relay. This function is useful to open an electrovalve before/after the dosing time. "Before" means that output is activated 4 seconds before the program ends. "After" means that output is activated 5 seconds after the program ends. Use "UP" key to change selected value. If entered value is greater than 60 seconds the pump will change unit from seconds to minutes.

### ***Password option:***

The display shows:

Modify Password  
->0 0 0 0

This is the password to protect access to program mode. Press "RIGHT" key to scroll through the numbers and enter proper code. Default code is 0000. Press "E" key to enter.

---

## Programming the pump

---

### **Supply Volt.:**

Not editable. It shows (real-time) the power supply voltage according to pump's working range.

### **Run-Mode:**

To exit from programming mode.

### **HOW TO RESET THE PUMP ?**

Unplug pump's power cable from supply and while pressing "UP" and "RIGHT" keys connect the pump's power cable.

Checksum Error  
Make Setup  
Press any key to continue

By pressing any key the pump will restore itself to its default values. To not proceed with reset unplug power supply.

To reset all counters repeat the same procedure but use "RIGHT" and "E" key.

***Remember that after pump's reset all programming values, inject value, date and time, etc have been deleted and must be entered again.***

### **MANUAL MODE**

Unplug the pump from the main power. Keep pressed "UP" and "E" keys. Plug in the pump. Release both the keys. The pump will dose at its maximum capacity. Unplug the pump from main power to return into normal operational mode.

### **PRIMING MODE**

Keep pressed the "UP" key to priming the product to dose. Release it to return into normal operating mode.

***If pump does not dose and main green led is off:***

- check power supply cable.
- check correspondence between network voltage and pump voltage.
- check if fuse is blown.

***If pump does not dose and main red led is on :***

- check if there is enough additive to dose.
- check level's probe and avoid the suction of dirty materials.

***If the pump does not dose and the main green led is blinking:***

- check foot filter.
- remove air from pump head (see "Basic operations" chapter).
- remove dirty materials from suction and delivery valves (see "Maintenance" chapter).
- check if valve's o-ring are not swollen or crumbled. Otherwise should be a chemical incompatibility between elastomer and product to dose (see "O rings" chapter).

***If pump blown fuse after a few seconds of operation:***

- check correspondence between network voltage and pump voltage.
  - check pump's main board using a light with adequate voltage on solenoid's output
- If light does not pulse replace the main board (see "Electronic boards connections" chapter).

### **PUMP'S MESSAGES**

During normal operating mode, the pump may show some messages.

**Message:** "LOW VOLT"

**Description:** The pump is low voltage powered. Check main power.

**Message:** "HIGH VOL"

**Description:** The pump is high voltage powered. Check main power.

**Message:** "LOW LEVEL"

**Description:** Product to dose is near to end. Verify the tank.

**Message:** "STAND-BY"

**Description:** The pump is waiting (a specified time) to become operative. See related chapter to set this function.

---

## O-rings, Maintenance and Repair Operations

---

### O RING

The valve sealings are provided in 5 different types to satisfy different chemical compatibility issues. The elastomer that will best fit the requested need can be found on the Manufacturer compatibility table. Get in touch with customer support if needed. The elastomer used for the o-rings equipping the "FMS Digital" pumps are characterized by different suction/delivery valve colours.

<i>Elastomer</i>	<i>ISO Code</i>	<i>Manufacturer Code</i>	<i>Valve Colour</i>
Fluorocarbon	FPM	FP	black
Ethylene propylene	EPDM	EP	grey
Polytetrafluoroethylene	PTFE	PTFE	blue
Nitrile	NBR	WAX	green
Silicone	MVQ	SI	yellow

### MAINTENANCE

Every month (when in normal use) pump and accessories should be checked for proper operation. For a correct maintenance, please perform following tasks:

- check electrical connections
- check liquid end screws
- check discharge line connections
- check discharge and suction valve connections
- check the entire liquid end for leakage
- check feed rate: run the pump for a short period in priming mode

### REPAIR



**All repair measures must be performed by authorized and qualified personnel. If pump needs to be repaired in manufacturer's factory send it only if it has been cleaned and after the liquid end has been rinsed!**

If, despite pump's emptying and cleaning, there are still possible safety hazards the information must be declared on return's form!

**If pump needs a replacement use only ORIGINAL spare parts!**

Replacing discharge valve:

- remove discharge line
- unscrew discharge valve from the liquid end
- remove oring from the liquid end
- screw in the new discharge valve with oring up to the stop
- refit discharge line

### TECHNICAL FEATURES

<i>Number of pump injections:</i>	0 ÷ 150 injections/minute
<i>Suction Height:</i>	1,5 metres
<i>Environment Temperature:</i>	0 ÷ 45°C (32 ÷ 113°F)
<i>Chemical Temperature:</i>	0 ÷ 50°C (32 ÷ 122°F)
<i>Installation Class:</i>	II
<i>Pollution Level:</i>	2
<i>Packaging and shipping temperature:</i>	-10 ÷ 50°C
<i>Audible noise:</i>	74dbA

### MANUFACTURING MATERIALS

<i>Case:</i>	PP
<i>Pump head:</i>	PP (available in PVDF)
<i>Diaphragm:</i>	PTFE
<i>Balls:</i>	CERAMIC (available in glass and PTFE)
<i>Suction Pipe</i>	PVC (available in PE)
<i>Delivery Pipe:</i>	PE
<i>Valve Body:</i>	PP (available in PVDF)
<i>O-ring:</i>	as ordered (FP, EP, WAX, SI, PTFE)
<i>Injection connector:</i>	PP (available in PVDF) (glass balls, HASTELLOY C276 spring).
<i>Level Probe:</i>	PP (available in PVDF)
<i>Level probe cable:</i>	PE
<i>Foot Filter:</i>	PP (available in PVDF)

# Exploded View

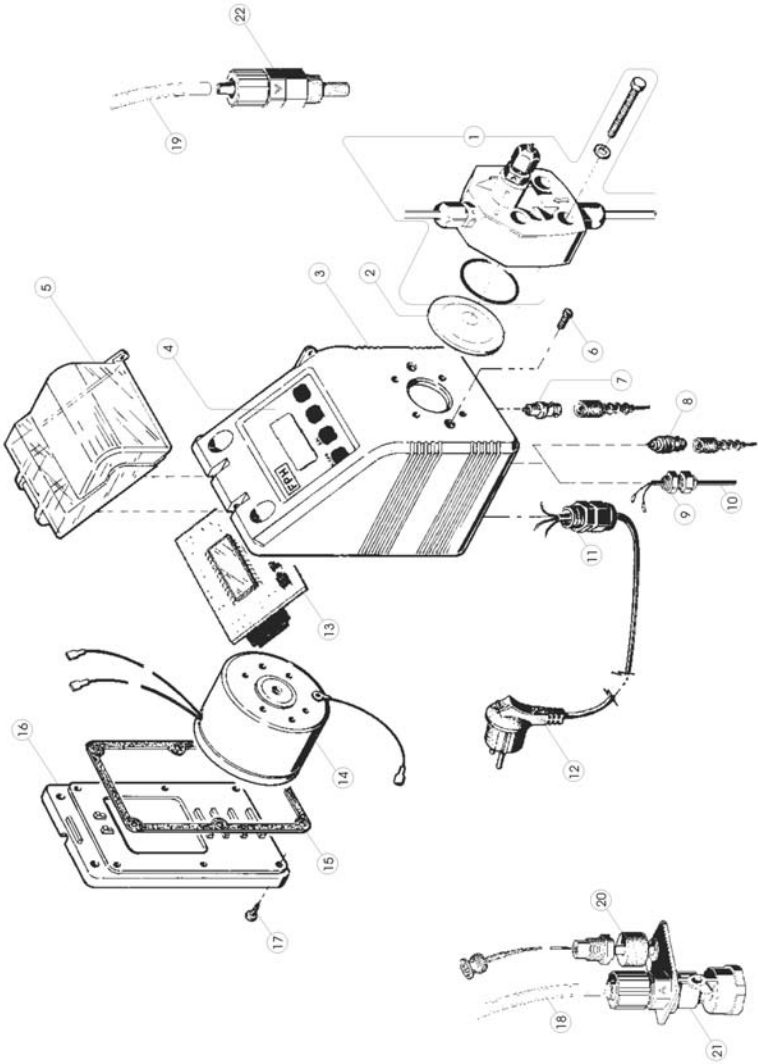

**Notice:** always specify the pump's label when ordering spare parts.

**Dimensions for "FMS" series Solenoid metering pumps**

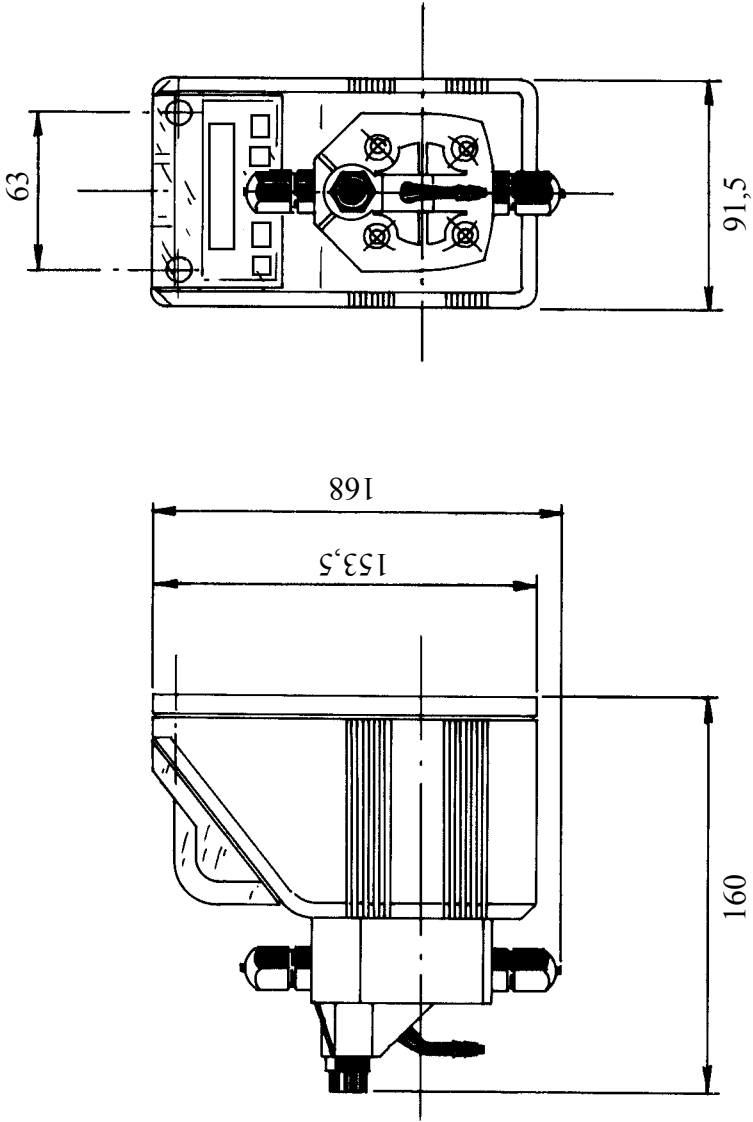

# Setup Diagram for "FMS PH/RH" solenoid metering pumps

- 1 - Injection Valve
- 2 - Sampler Point
- 3 - Ph/Rh Probe
- 4 - Probe Holder
- 5 - Metering Pump
- 6 - Level Probe
- 7 - Foot Filter
- 8 - Power Supply Cable
- 9 - Safety Breaker
- 10 - Filter
- 11 - Delivery Hose
- 12 - Suction Hose
- 13 - Outgassing Hose

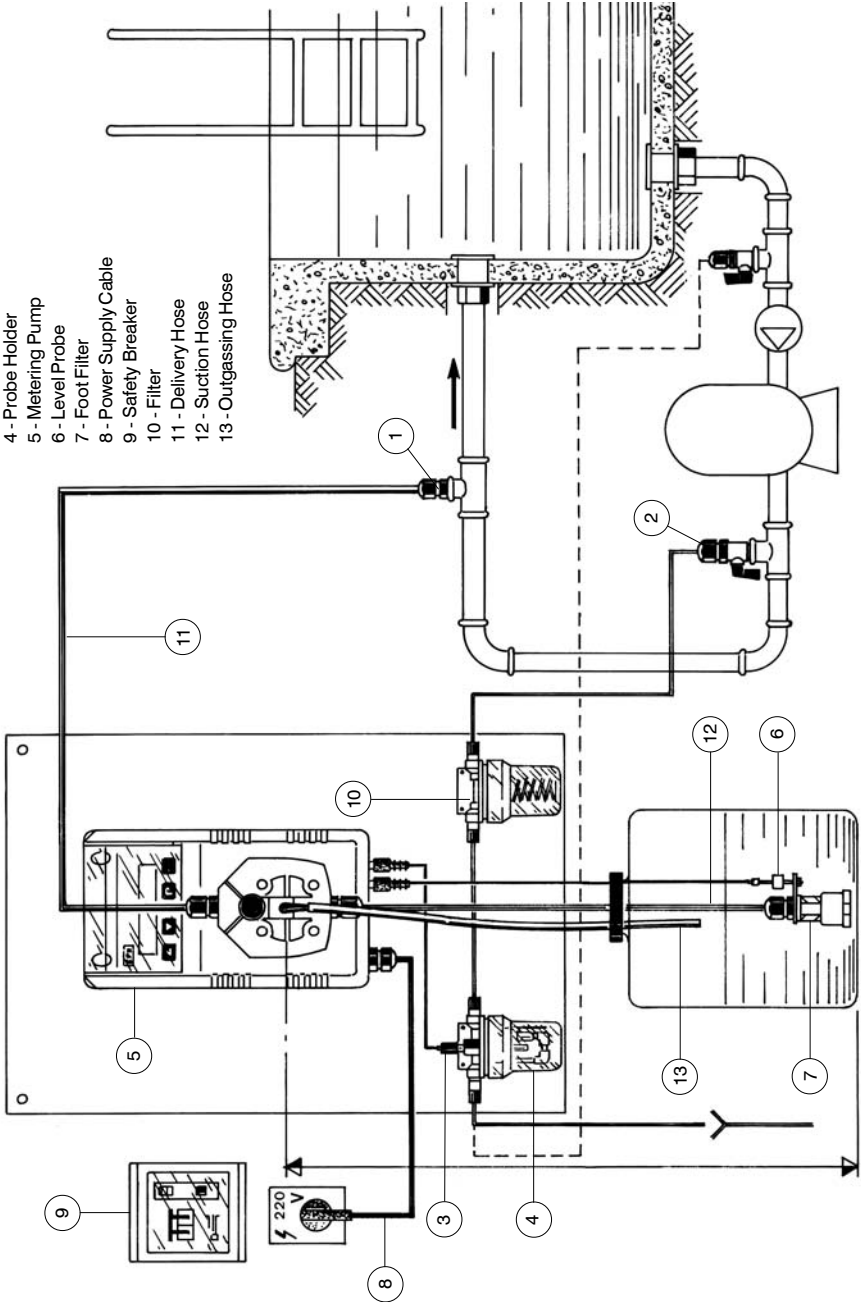

# Setup Diagram for "FMS PH/RH" solenoid metering pumps

- 1 - Injection Valve
- 2 - Ph/Rh Probe
- 3 - Metering Pump
- 4 - Level probe
- 5 - Foot Filter
- 6 - Power Supply Cable
- 7 - Safety Breaker
- 8 - Delivery Hose
- 9 - Suction Hose
- 10 - Outgassing Hose

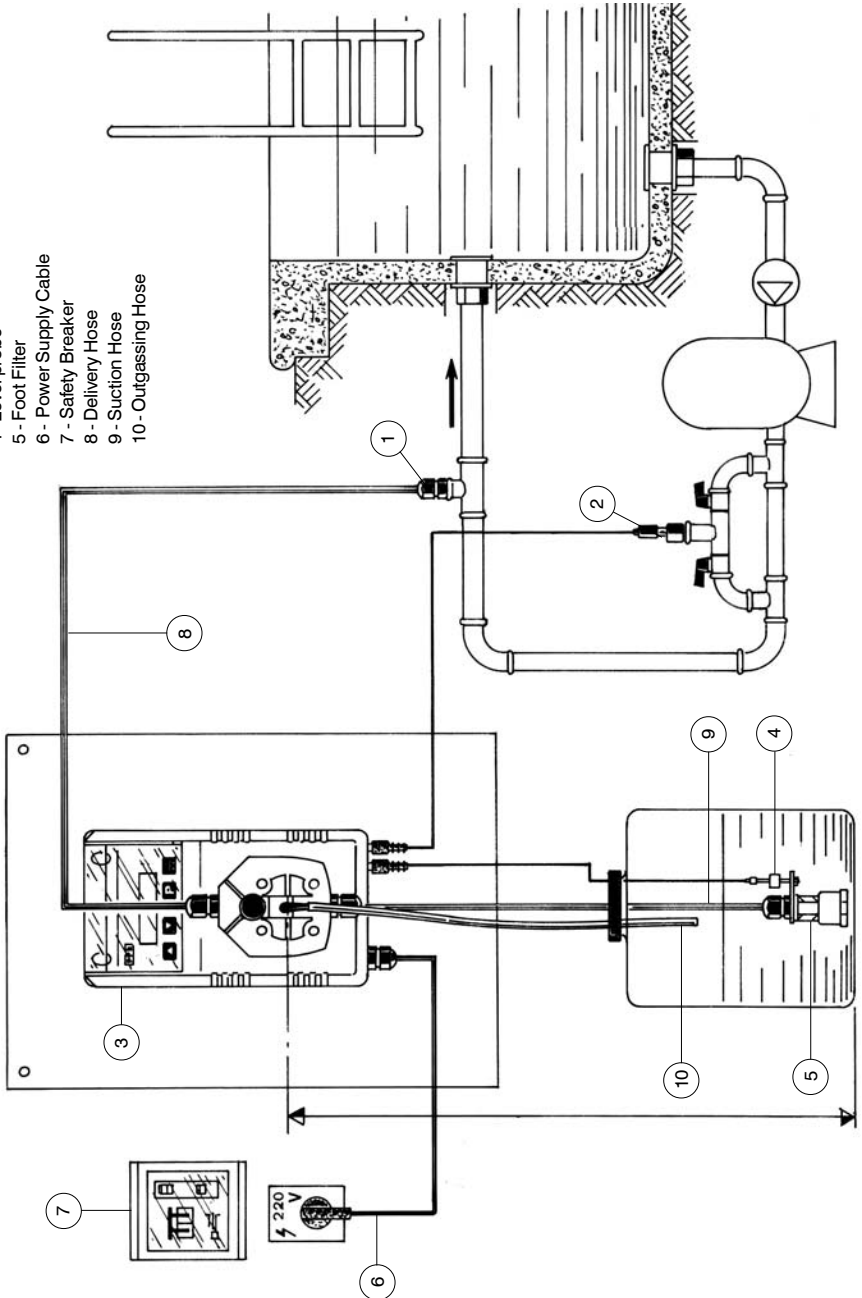

# Setup Diagram for "FMS EN" solenoid metering pumps

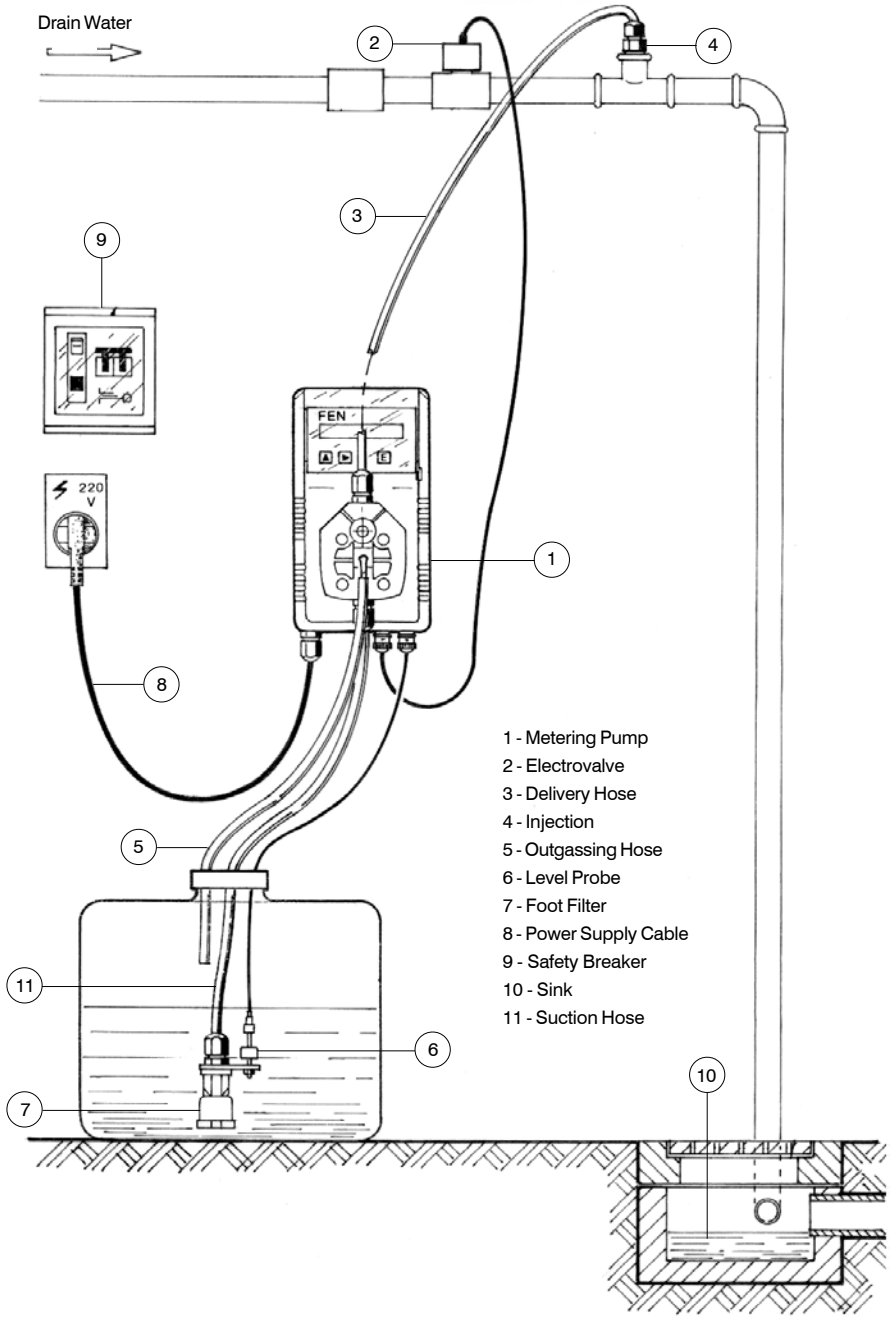

<b>Recommended Chemicals Table</b>		
<i>Chemical Product</i>	<i>Formula</i>	<i>Maximum % Concentration</i>
Hydrochloric Acid	<b>HCl</b>	33%
Sulphuric Acid	<b>H<sub>2</sub>SO<sub>4</sub></b>	96%
Sodium Bisulphate	<b>NaHSO<sub>4</sub></b>	37%
Sodium Chlorite	<b>Na ClO<sub>2</sub></b>	30%
Sodium Hypochlorite	<b>Na OCl</b>	13,5%
Calcium Hypochlorite	<b>Ca (ClO)<sub>2</sub></b>	2%
Dichloroisocyanuric Sodium	<b>(CON)<sub>3</sub> Cl Na</b>	4%
Alluminium Sulphate	<b>Al<sub>2</sub> (SO<sub>4</sub>)<sub>3</sub></b>	18%
Ferric Chloride	<b>Fe Cl<sub>3</sub></b>	40%

NSF Listed units must be used with Sodium Hypo Chlorite.

# Delivery Curves

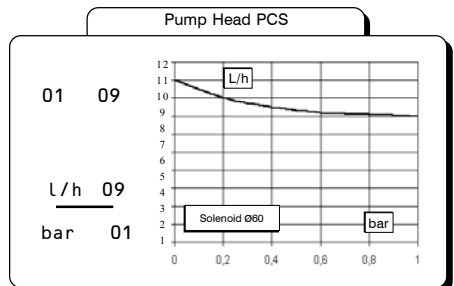
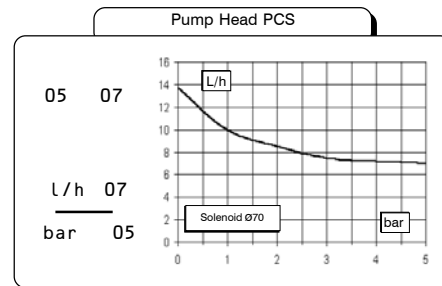
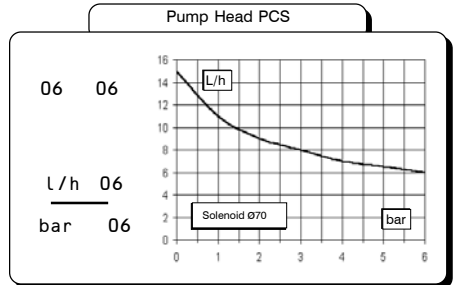
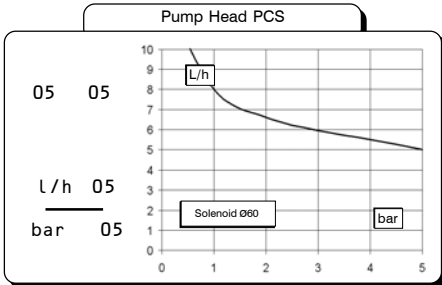
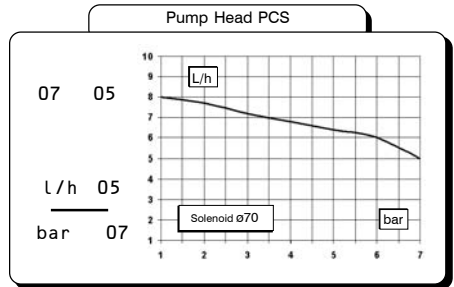
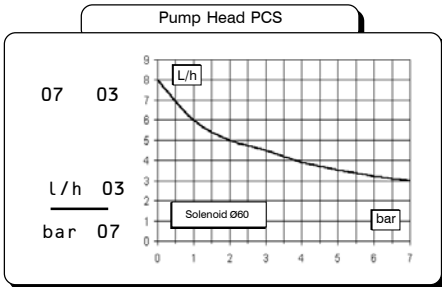
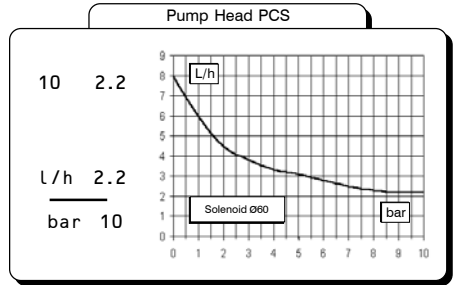
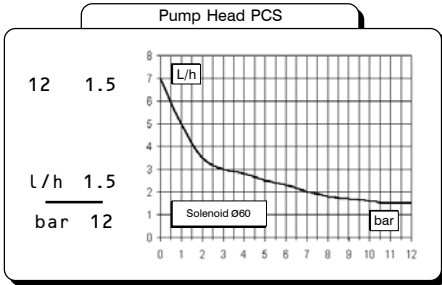

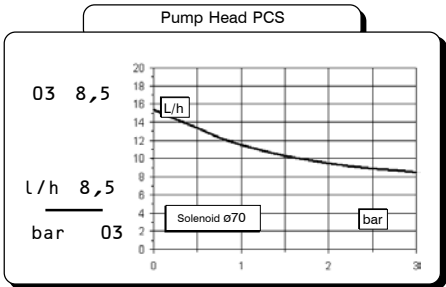
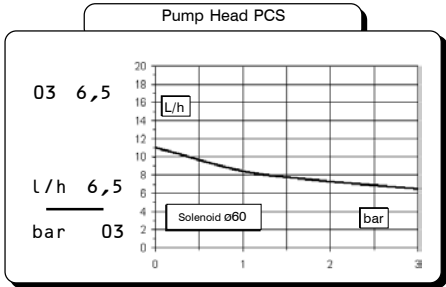
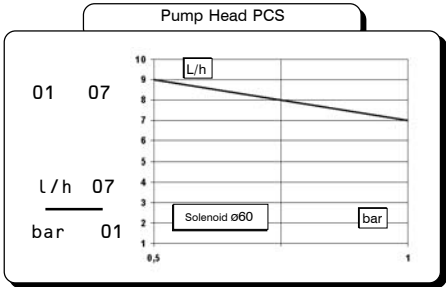

Flow rate indicated is for H<sub>2</sub>O at 20 °C at the rated pressure. Dosing accuracy ± 2% at constant pressure ± 0,5 bar.

---

---

## Auto-venting pump head

This pump head removes the gas from gaseous chemicals during operation, independently of back pressure.

Attention: valves cannot be changed from their original position.

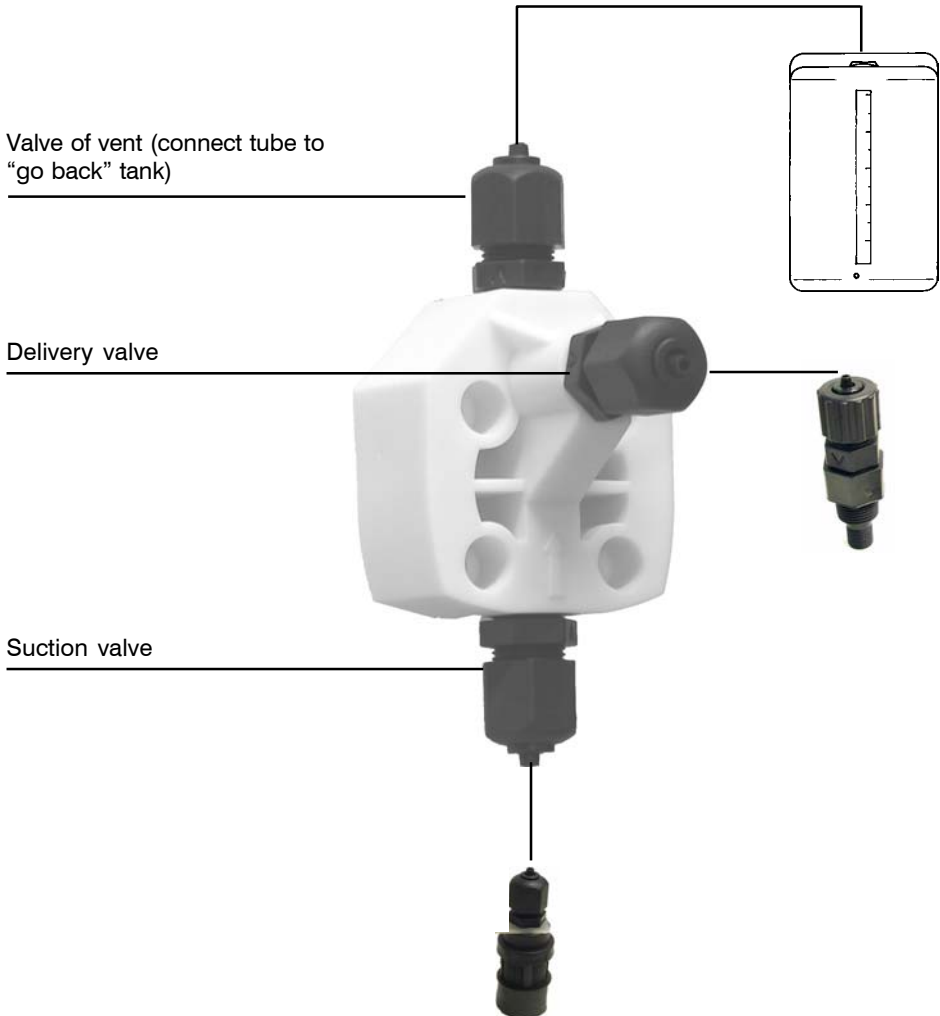

---

---

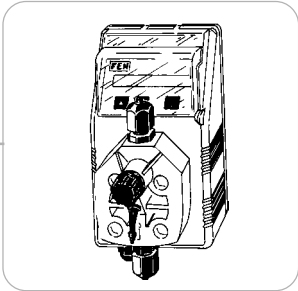

*When dismantling a pump please separate material types and send them according to local recycling disposal requirements.  
We appreciate your efforts in supporting your local Recycle Environmental Program.  
Working together we'll form an active union to assure the world's invaluable resources are conserved.*