

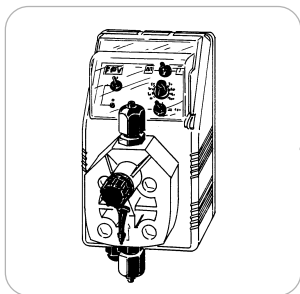

This operating instructions contains safety information that if ignored can endanger life or result in serious injury. They are indicated by this icon.



Use of this pump with radioactive chemicals is forbidden!



## OPERATING INSTRUCTIONS MANUAL FOR “F” and “FA” PUMPS



Keep the pump protected from sun and water.  
Avoid water splashes.

Please read it carefully!



English language

R1-03-04

## «CE» referring norms



“F” and “FA” series dosing pumps comply with the following European regulations:

EN60335-1 : 1995, EN55014, EN50081-1/2, EN50082-1/2, EN6055-2, EN60555,3

Based on directive CEE 73/23 c 93/68 (DBT Low voltage directive) and directive 89/336/CEE (EMC Electromagnetic Compatibility)



All metering pumps with 230 VAC and 115 VAC power supply with FP o-rings are listed NSF 50 (except for 10 05, 05 10, 05 0,2, 03 11, 03 6,5 and 03 8,5 models).



## GENERAL SAFETY GUIDELINES

### Danger!

In emergencies the pump should be switched off immediately! Disconnect the power cable from the power supply!

When using pumps with aggressive chemicals observe the regulations concerning the transport and storage of aggressive fluids!

When installing outside European Community, always observe national regulations!

Manufacturer is not liable for any unauthorized use or misuse of this product that can cause injury or damage to persons or materials!

### Caution!

Pumps must be accessible at all times for both operating and servicing. Access must not be obstructed in any way!

Feeder should be interlocked with a no-flow protection device to automatically shut-off the pump when there is no flow!

Pumps and accessories must be serviced and repaired by qualified and authorized personnel only!

Always discharge the liquid end before servicing the pump!

Empty and rinse the liquid end before work on a pump which has been used with hazardous or unknown chemicals!

Always read chemical safety datasheet!

Always wear protective clothing when handling hazardous or unknown chemicals!

# Index

GENERAL INFORMATION .....	4
INSTALLATION .....	4
PRIMING (ONLY “F” SERIES PUMPS) .....	5
METERING .....	5
ELECTRICAL WIRING .....	5
ELECTRICAL PROTECTION .....	6
LEVEL ALARM .....	7
PUMP TYPES .....	7
MAINTENANCE .....	11
REPAIR .....	11
QUICK TROUBLESHOOTING GUIDE .....	12
O-RINGS .....	12
TECHNICAL FEATURES .....	12
CONSTRUCTION MATERIALS .....	13
ACCESSORIES .....	13
PRINTED CIRCUIT BOARD CONNECTION .....	14
CAPACITY CURVES .....	15
“F” AND “FA” SERIES PUMP INSTALLATION DRAWINGS .....	18
“F” AND “FA” SERIES PUMP INSTALLATION DRAWINGS .....	19
“F” AND “FA” SERIES PUMP EXPLODED VIEW .....	20
“F” SERIES COMMANDS DESCRIPTION .....	21
“FA” SERIES COMMANDS DESCRIPTION .....	23
DIMENSIONS .....	23
AUTO-VENTING PUMP HEAD .....	25



**Technical features and drawings are subject to changes and modifications without any advice.**

## GENERAL INFORMATION

“F” and “FA” series magnetic diaphragm dosing pumps fits small dosing amounts of liquid products. They are constituted of the following main assemblies:

*Box*  
*Electronic Circuitry*  
*Electrical Driven Magnet*  
*Diaphragm*  
*Pump Head*

The pump working mode is intermittent: a magnetic field is created each time a pulse reaches the magnet. The magnetic field pushes the piston. A diaphragm (fixed on the piston head) compresses the liquid into the pump head. The liquid gets out through the delivery valves while the suction valves close. When the pulse ends, a spring takes back the piston and the diaphragm. The vacuum created by the diaphragm movement takes the liquid inside the pump head from the suction valve, while the delivery valve is closed. The pump capacity is proportional to the number of strokes and to the pump head internal volume (Single Stroke Injection Quantity).

### *Box*

“F” and “FA” series dosing pumps are assembled in IP65 (PP) plastic material boxes. Installation is vertical with two screws at a distance of 63mm.

### *Electronic Circuit*

The electronic circuit is made of proved quality components. It provides the necessary electrical pulses to the magnet.

### *Electro-Magnet*

The electro-magnet with class H (180°C) copper winding, driven by the electronic circuit, gives the necessary push to the piston and the diaphragm. The piston displacement range is from 0.7mm to 1.7mm.

### *Diaphragm*

PTFE diaphragms used in the series “F” and “FA” pumps assure good chemical compatibility and mechanical resistance.

### *Pump Head*

The pump head works as a dosing chamber, the suction valve, delivery and manual outgassing valves are inside it. The purpose of the manual outgassing valve is to help the priming of the pump during installation.

## INSTALLATION

The pump is supplied with all the components needed for the installation. To set up the “F” and “FA” series pump, first mount it on a wall or any other vertical surface in a well aerated and easily accessible environment. The distance between the pump head and the suction filter should not be more than 1.5m. Connect the suction pipe (transparent one) to the suction fittings (bottom pump head valve). Be sure the o-ring in the suction valve is in place. Use the hands to tight the fitting nut. Place the suction filter on the bottom of the product tank. The suction pipe should be as short as possible in vertical position without any bends to avoid air bubbles. Install the injection valve. Connect one end of the delivery pipe (opaque one) to the delivery fitting on the top of the pump head and the other end to the injection valve previously installed. Please refer to pages 17-19 for setup diagrams.



**To avoid delivery pipe breaking be sure it doesn't touch any other object.**

Always install the injection valve at the end of the rigid delivery hose. The injection valve should never be installed lower than the product tank to avoid that injection valve breaking lets the product flow freely into the system. It is recommended to use an anti-syphon valve on the delivery side if the only way to install the injection valve is lower than the tank. This valve prevents vacuum on the pump. Feeder should be interlocked with a no-flow protection device to automatically shut-off the pump when there is no flow. Check regularly the delivery valve status and immediately change it if inoperable or broken. Do not install tanks with chemical beneath the pump: vapours may damage the pump.

**FREE END OF SUCTION HOSE SHOULD BE INSERTED JUST ABOVE THE BASE OF NOOZLE!**



**USE ONLY HOSES COMPATIBLES WITH PRODUCT TO DOSE. PLEASE REFERS TO OUR "CHEMICAL COMPATIBILITY TABLE"!**

### **PRIMING (Only "F" series pumps)**

To prime the pump without touching chemicals please do as follow:

- connect all hoses into proper places (delivery hose, suction hose, outgassing hose).
- open outgassing valve and turn on the pump.
- set pump's single injection at 100% and pulses at 50%.

All air inside the pump head will exit through the outgassing outlet. When product will leak from it, close immediately the outgassing valve. If dosing product is particularly dense, to facilitate the priming, insert on vent pipe a syringe of 20 cc and suck inside.

**"FA" series pumps are equipped with automatic venting heads and doesn't need priming procedure.**

### **METERING**

The "F" and "FA" series pump technical features are printed on a label located at the left side of pump box. They include: power supply, working counterpressure (Kpa/bar) and pump capacity in liter per hour (l/h). All these dosing information are calculated by dosing water at 20 °C temperature, at the maximum counterpressure reported on the label, using the injection valve and the % knob set to maximum. Dosing accuracy is  $\pm 2\%$  l/h at constant maximum counterpressure and 1 cps flow (**max viscosity: 60 cps**).



**Caution: injection capacity is a constant value but a variation in counterpressure or product's viscosity may cause some changes. For further details see "delivery curves" paragraph.**

### **ELECTRICAL WIRING**

Pump has to be connected to power supply using the standard "SCHUKO" plug supplied or the special power supply cable.

**Before starting any electrical connection perform the following operations:**



- **ensure a correct ground installation\***;
- **if there is a bad ground, install a differential switch with high sensibility (0,03 A) as additional protection from electric shocks\***;
- **check that pump voltage corresponds to supply voltage;**
- **connect ground before any other connection\***.

\* 230/115 VAC models only.

Electrical features:

Power supply range for 230 V models	198 ÷ 242 VAC
Power supply range for 115 V models	99 ÷ 121 VAC
Power supply range for 24 V models	20 ÷ 27 VAC



**Do not connect the pump in parallel to an inductance load, e.g. motors, to prevent electronic circuitry damages. Always use a connector to cut off spikes due to other devices switching.**

### Dosing pump in parallel connection with inductive loads

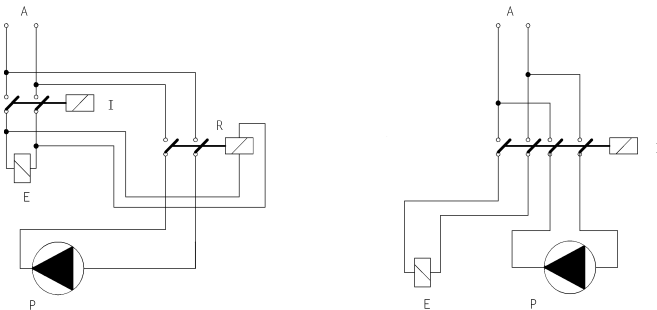

P - Metering Pump

R - Relay

I - Connector or Multi-Pole Safety Device

E - Inductance Load

A - Power Supply

## ELECTRICAL PROTECTION

Internal circuitry is protected against noises using the EMC system and with a fuse located under the front cover of the pump. To replace the fuse (**trained personnel only**) do as follow:

- **unplug power supply**
- **remove the 6 screws on the back cover of the pump**
- **replace fuse, use only approved fuses reported in table below**
- **put back cover in place, take care of seal position**

Each pump type fuse (**5x20**) **T(delayed)** can be found in table below:

<b>Model</b>		<b>Consumption at 230 and fuse</b>	<b>Consumption at 115 and fuse</b>	<b>Consumption at 24</b>
<b>Fxx</b> 12 1,5		230 VAC / 630 mA 16W	115 VAC / 315 mA 11W	24 VAC / 2 A
<b>Fxx</b> 10 2,2	<b>FAxx</b> 10 1,4	230 VAC / 630 mA 16W	115 VAC / 315 mA 11W	
<b>Fxx</b> 07 03	<b>FAxx</b> 07 2,2	230 VAC / 630 mA 16W	115 VAC / 315 mA 11W	24 VAC / 2 A
<b>Fxx</b> 07 05	<b>FAxx</b> 07 3,5	230 VAC / 800 mA 16W	115 VAC / 500 mA 13W	
<b>Fxx</b> 05 05	<b>FAxx</b> 05 3,5	230 VAC / 630 mA 16W	115 VAC / 315 mA 11W	24 VAC / 2 A
<b>Fxx</b> 06 06	<b>FAxx</b> 06 4,5	230 VAC / 800 mA 16W	115 VAC / 500 mA 13W	
<b>Fxx</b> 05 07	<b>FAxx</b> 05 05	230 VAC / 800 mA 16W	115 VAC / 500 mA 13W	
<b>Fxx</b> 01 07	<b>FAxx</b> 01 05	230 VAC / 630 mA 16W	115 VAC / 315 mA 11W	24 VAC / 2 A
<b>Fxx</b> 01 09	<b>FAxx</b> 01 6,5	230 VAC / 800 mA 16W	115 VAC / 500 mA 13W	
<b>Fxx</b> 10 05		230 VAC / 800 mA 19W		
<b>Fxx</b> 05 10		230 VAC / 800 mA 19W		
<b>Fxx</b> 05 0,2		230 VAC / 630 mA 16W	115 VAC / 315 mA 11W	
<b>Fxx</b> 03 11		230 VAC / 800 mA 19W		
<b>Fxx</b> 03 6,5		230 VAC / 630 mA 16W		
<b>Fxx</b> 03 8,5		230 VAC / 800 mA 16W		

“F” and “FA” series pumps are equipped with an overvoltage protection (working voltages: 300 V, 150V, 39V) and a voltage peak protection up to 4 KV, 50  $\mu$ sec against pulses as shown in fig. 1.

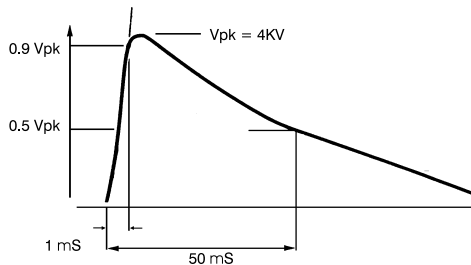

fig. 1

## **REPAIRS MUST BE PERFORMED BY AUTHORIZED PERSONNEL ONLY**

### **LEVEL ALARM**

CL, IS, IC, PV, TE and PVM type pump are provided with a liquid level alarm to indicate product tank is empty. The level probe is connected to the right BNC plug on pump's bottom panel. The level probe is made of a N.O. reed contact (10VA, 1A max., 230Vac max.) closed by a floating magnet housed in a (PP) plastic box. When the product level goes below the minimum the magnet closes the reed contact. The pump stops and the red LED on pump's front panel indicates the alarm status.

### **PUMP TYPES**

*Pumps mod. "FCLF", "FCL" (12-24 Vac/Vdc), "FIC", "FIS", "FPV" and "FPVM" are equipped with a bicolour led.*

*Led on, red colour: low level product alarm. Check product's tank and restore the level.*

*Led on, blinking green colour: pump normal operating mode.*

*Led on, blinking green colour (one second on, one second off): power supply out of range. Check pump's label and check the main power.*

#### **-FCO -**

*Constant* dosing pump with stroke speed adjustment between 0 and 100% of indicated capacity (see label on pump type). The % marked knob sets the pump capacity, changing linearly the magnet stroke number per minute. It is strongly suggested to not operate the pump in the range from 0 to 10%, since there is not a linear correlation with the pump stroke speed in that range. This pump is specially designed for constant dosing rates. FCO pump can be ON/OFF driven by an LPH or a LCD instrument. To set 2.5 l/h against 5 bar on a FCO 0505 the % marked knob should be set to 50%. FCOF have a divider (x- 0,1) to reduce ten times the pump capacity dividing by ten the pump stroke speed.



#### **-RFCO-**

*Constant* dosing pump with stroke speed adjustment between 0 and 100% of indicated capacity (see label on pump type). The electronic capacity adjustment and the 20% - 100% switch sets the injection per minute. 20% - 100% switch to 100 % sets the maximum capacity of the pump, 20% - 100% switch to 20% sets the maximum capacity to be a 1/5 of the pump maximum capacity. This pump does not have an ON/OFF switch, power supply present is shown by a green LED on.

#### **-FCL -**

*Constant dosing pump with level alarm*, provided with a floating magnetic sensor probe. A red led indicates that the pump stops dosing because the product tank is empty. This pump has the same features and adjustments of the CO type pump.



#### **-FIC -**

*Proportional/constant* pump driven by current signal. Setting the switch on the *constant*  position, the pump has the same features and adjustments of the CL pump. Setting the switch on the *proportional*  position, the pump capacity is set proportionally to a given analog current signal; a given signal linear change will be followed by a linear change of capacity.

The current signal accepted range is 0÷20 mA (it can be changed upon demand). The maximum pump capacity requested by the maximum input signal is set by the % marked knob. The IC pump can be driven by any electronic device (such as pH-meter, redox-meter, etc) that gives an analog current signal output. This signal must be applied to the bipolar cable provided with the pump, already internal connected, taking care of connections:



- Red wire : *positive (+)*
- Black wire : *negative (-)*

#### **-FIS -**

*Proportional/constant* pump driven by a digital signal. Setting the switch on the *constant*  position, the pump has the same features and adjustments of the CL pump. Setting the switch on the front panel in the *proportional*  position, to each external voltage free pulse correspond a magnet stroke. When proportional position is set, the % marked knob does NOT affect the pump capacity. IS proportional dosing pump can be driven by any external device (PCs, PLCs, etc) that produce a digital signal. This digital signal (N.O. contact) must be applied to the cable provided with the pump, already internal connected. If it is requested a 0÷5 ; 0÷12 Vdc input signal option, take care of connections:

- Red wire : *positive (+)*
- Black wire : *negative (-)*

#### **- FPV -**

*Proportional/constant* pump driven by a water meter digital signal. Setting the switch on the *constant*  position, the pump has the same features and adjustments of the CL pump. It is furthermore possible to divide the maximum magnet strokes per minute by 1, 10 and 100 using the switch on the front panel. Setting the switch on the *proportional*  position, to each external pulse correspond one pump stroke. This pump can be driven by a CTFI or CWFI series water meters. This pump can also



be driven by a digital signal coming from a voltage free contact. Driving signal is applied on the BNC plug on the left bottom of the front cover. Dividing factor (N) value is obtained multiplying the value on the adjustment knob by the multiplying switch (x1, x10, x100) value.

*Capacity definition for “FPV” and “FAPV” pump*

Given the water m<sup>3</sup> to be treated and the product amount to dose in p.p.m., the minimum pump capacity to be used can be obtained with the following formula:

$$\frac{\text{ppm} \times K \times \text{m}^3}{1000} = \text{l/h}$$

*l/h* - minimum pump capacity required  
*ppm* - product amount to dose in p.p.m. (gr/m<sup>3</sup>)  
*k* - dosed product dilution factor (pure chemical k=1)  
*m<sup>3</sup>* - maximum capacity of the system to be treated in m<sup>3</sup> /h.

Dividing factor (N) to be set on the adjustment knob is given by the following:

$$\left( \frac{\text{imp/l} \times \text{cc}}{\text{ppm} \times K} \right) \times 1000 = N$$

*N* - is the number the external pulses are divided by to be set on the adjustment knob  
*imp/l* - pulse per liter given by the water meter  
*cc* - pump's single stroke dosing quantity (in cc). Refer to following table  
*k* - dosed product dilution factor (pure chemical k=1)  
*ppm* - product quantity to be dosed in p.p.m. (gr/m<sup>3</sup>)

<b>Fxx</b>	<b>cc</b>	<b>FAxx</b>	<b>cc</b>
12 1,5	0,17	10 1,4	0,16
10 2,2	0,25	07 2,2	0,25
07 03	0,34	07 3,5	0,39
07 05	0,56	05 3,5	0,39
05 05	0,56	06 4,5	0,5
06 06	0,67	05 05	0,56
05 07	0,78	01 05	0,56
01 07	0,78	01 6,5	0,73
01 09	1,25		
10 05	0,56		
05 10	1,00		
05 0,2	0,25		
03 11	1,10		
03 6,5	0,72		
03 8,5	0,94		

If the dividing factor (N), obtained with the above formula, is <1, a pump with higher single stroke dosing quantity is required or the water meter needs to be changed with one that gives higher number of pulses per liter or using a “FPVM” or “FAPVM” pump. In some application this issue can be solved reducing the dosed product dilution factor. If dosed amount is higher than the needed one, the set dividing factor (N) can be increased.

**- FPVM -**

*Proportional/constant* pump driven by a water meter digital signal. Setting the switch on the *constant*  position, the pump has the same features and adjustments of the CL pump. It is furthermore

possible to divide the maximum magnet strokes per minute by 1 ( $\div 1$ ), 10 ( $\div 10$ ) and 100 ( $\div 100$ ) using the selector on the front panel. The electronic capacity adjustment sets the injection per minute. Setting the switch on the *proportional*  position and the selector on “multiplier” (X1), the pump gives a stroke each 10 external pulses sent. Setting the selector on “divider” ( $\div 1$  or  $\div 10$ ), the pump gives at maximum a stroke each external pulse sent and at minimum a stroke each 100 pulses sensed (knob  $n=10$ , switch  $\div 10$ ). This pump can be driven by a CTFI or CWFI series water meters. This pump can also be driven by a digital signal coming from a voltage free contact. Driving signal is applied on the BNC plug on the left of the bottom pump cover. “FPVM” and “FAPVM” capacities are defined by the same formulas used for “FPV” and “FAPV”.

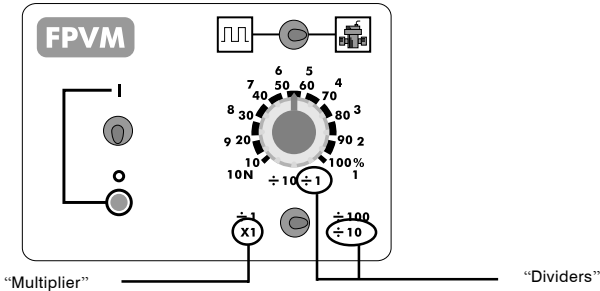

**-FTE-**

*Timered/constant* dosing pump. Setting the switch on the *constant* position, the pump has the same features and adjustments of the CL pump. Setting the switch on *timered* , the pump starts working when an external pulse is provided. Working active time for each external pulse is set on the adjustment knob in the range between 0 and 60 seconds (different time are available upon demand). The capacity can be also changed adjusting the stroke per minute, operating the % marked knob, at the same time. The double parameter adjustment (strokes and time) allows the use of this pump in high capacity systems, where the pulses are not enough to drive a PV type pump. TE pump is provided of a coaxial cable (RG58) with BNC plug to connect the command signal. Use following formula to evaluate the knob adjustment:

$$\frac{3600}{\text{imp/h}} = \text{sec.}$$

*imp/h* - water meter output pulse per hour  
*sec* - time in seconds to be set on time knob

Maximum tag capacity can be decreased 10 or 100 times in the “F” and “FA” pumps using the 1/10/100 switch (where available). In that case the % marked knob will work on the maximum set capacity.

**-FPDR-**

Intermittent constant metering pump with adjustable pause and work times. Metering is set using three knobs on the front panel:

- (%) knob (red coloured range) sets speed stroke
- (10 ÷ 180 seconds) Pause knob sets time between one metering and the next
- (10 ÷ 180 seconds) Work knob sets metering time

Once powered the pump, it always starts its working cycle metering for the set time. A N.O. (1A / 230Vac) service contact is active while metering. If the level input is active while the service contact

is active, pump stops and service contact gets back to N.O. *Service contact is available through a bipolar cable out of the pump.* Once refilled the tank or recovered the level input, the pump starts to dose for the remaining time missing to complete the set work time once stopped. Level alarm is showed on the front panel with a red LED on.

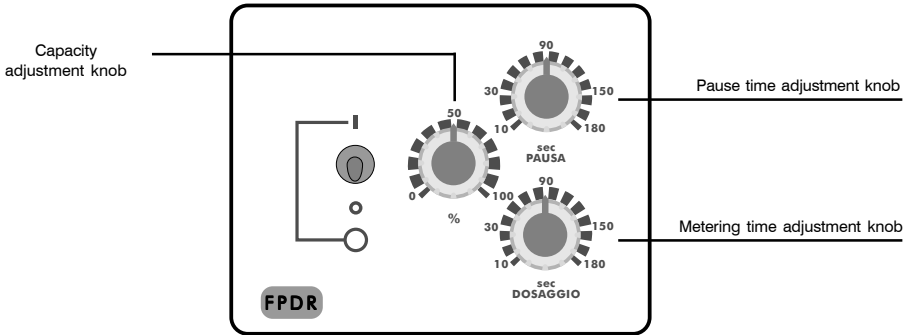

## MAINTENANCE

Every month (when in normal use) pump and accessories should be checked for proper operation. For a correct maintenance, please perform following tasks:

- check electrical connections
- check liquid end screws
- check discharge line connections
- check discharge and suction valve connections
- check the entire liquid end for leakage
- check feed rate: run the pump for a short period in priming mode

## REPAIR



**All repair measures must be performed by authorized and qualified personnel. If pump needs to be repaired in manufacturer's factory send it only if it has been cleaned and after the liquid end has been rinsed!**

If, despite pump's emptying and cleaning, there are still possible safety hazards the information must be declared on return's form!

***If pump needs a replacement use only ORIGINAL spare parts!***

Replacing discharge valve:

- remove discharge line
- unscrew discharge valve from the liquid end
- remove oring from the liquid end
- screw in the new discharge valve with oring up to the stop
- refit discharge line

## QUICK TROUBLESHOOTING GUIDE

*If...pump does not work and the magnet strokes:*

- check and verify foot filter is not obstructed with impurities and chemical crystals;
- some air can be in the pump head. Remove it as described in the PRIMING section;
- check and ensure suction and delivery valves are not obstructed with product crystals;
- check and verify valves o-ring are not swell or damaged, it's a clear evidence of chemical incompatibility with used products (see "o-rings" section).

*If...pump blows fuse after working a while:*

- check and ensure supplied power is the same reported in pump tag;
- check electronic circuitry connecting it to a lamp (of the right voltages) instead of the magnet. All connections are "quick lock" made so: it's a quick test to perform, if the lamp does not light intermittently the electronic PCB needs to be replaced;
- check and ensure magnet impedance is ( $\pm 5\%$ ) the tag one. If not replace it.

## O-RINGS

The valve sealings are provided in 5 different types to satisfy different chemical compatibility issues. The elastomer that will best fit the requested need can be found on the manufacturer compatibility table. Get in touch with customer support if needed. The elastomer used for the o-rings equipping the "F" pumps are characterized by different suction/delivery valve colours.

<i>Elastomer</i>	<i>ISO Code</i>	<i>Manufacturer Code</i>	<i>Valve Colour</i>
Fluorocarbon	FPM	FP	black
Ethylenepropylene	EPDM	EP	grey
Polytetrafluoroethylene	PTFE	PTFE	blue
Nytril	NBR	WAX	green
Sylicon	MVQ	SI	yellow

## TECHNICAL FEATURES

<i>Pump strokes per minute:</i>	0 ÷ 150 pulse for minute
<i>Max suction pipe lenght:</i>	1,5 meter
<i>Environment temperature:</i>	0 ÷ 45°C (32 ÷ 113°F)
<i>Chemical Temperature:</i>	0 ÷ 50°C (32 ÷ 122°F)
<i>Installation Class:</i>	II
<i>Pollution Level:</i>	2
<i>Packaging and transporting temperature:</i>	-10 ÷ 50°C
<i>Audible noise:</i>	74dbA



Single stroke injection dose:

<i>Fxx</i>	<i>cc</i>	<i>FAxx</i>	<i>cc</i>
12 1,5	0,17	10 1,4	0,16
10 2,2	0,25	07 2,2	0,25
07 03	0,34	07 3,5	0,39
07 05	0,56	05 3,5	0,39
05 05	0,56	06 4,5	0,5
06 06	0,67	05 05	0,56
05 07	0,78	01 05	0,56
01 07	0,78	01 6,5	0,73
01 09	1,25		
10 05	0,56		
05 10	1,00		
05 0,2	0,25		
03 11	1,10		
03 6,5	0,72		
03 8,5	0,94		

## CONSTRUCTION MATERIALS

<i>Case:</i>	PP
<i>Pump Head:</i>	PP/PVDF (upon demand)
<i>Diaphragm:</i>	PTFE
<i>Valve Balls:</i>	CERAMIC (GLASS or PTFE upon demand)
<i>Suction pipe:</i>	PVC
<i>Delivery pipe:</i>	PE/PVDF (upon demand)
<i>Valve body :</i>	PP/PVDF (upon demand)
<i>O-ring:</i>	as requested (FR, EP, WAX, SI, PTFE)
<i>Injection connector:</i>	PP V-706 (glass ball, HASTELLOY C276 spring).
<i>Level Probe:</i>	PP/PVDF (upon demand)
<i>Level Probe cable:</i>	PE
<i>Foot Filter:</i>	PP/PVDF (upon demand)

## ACCESSORIES

<b>n.2</b>	Dibbles ø6
<b>n.2</b>	Screws 4,5 x 40
<b>n.1</b>	Fuse 5 X 20 delayed
<b>n.1</b>	Foot filter/valve assy
<b>n.1</b>	Injection valve
<b>n.1</b>	Level probe (not included in model CO, RxCO and PDR)
<b>m 2</b>	Delivery hose in white opaque polyethylene
<b>m 2</b>	PVC or PE suction hose
<b>m 2</b>	Transparent PVC outgassing hose
<b>n.1</b>	Instruction manual

# Printed Circuit Board Connection

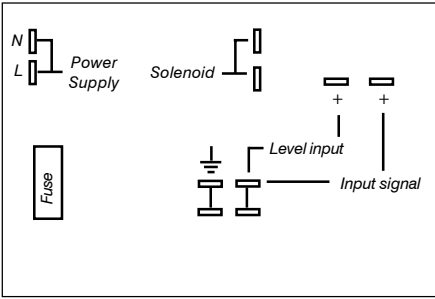

**Mod. FIC/FIS/FPV/FPVM**

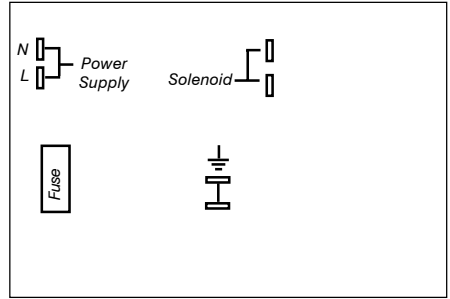

**Mod. FCOF**

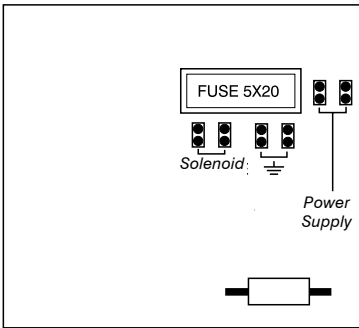

**Mod. FCO**

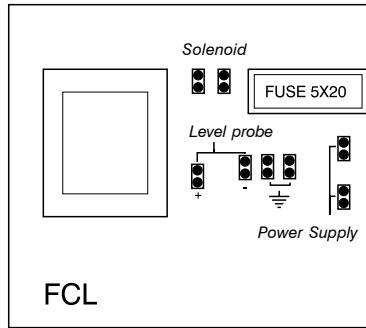

**Mod. FCL/FCLF**

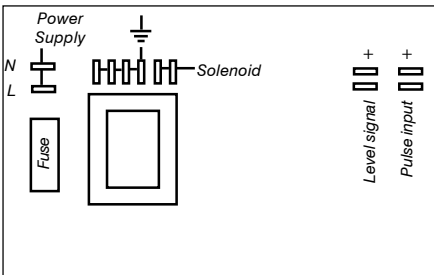

**Mod. FTE**

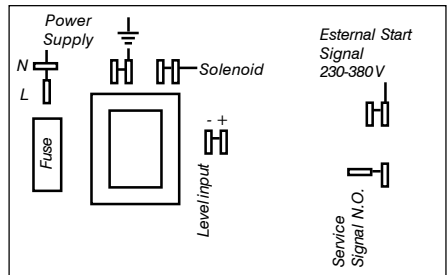

**Mod. FPDR**

# Capacity curves

Pump Head PCS

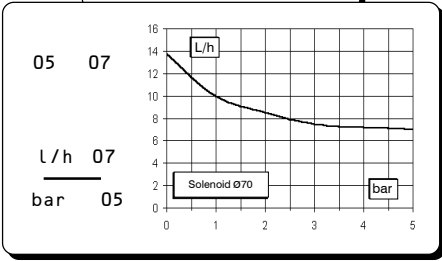

Pump Head PCS

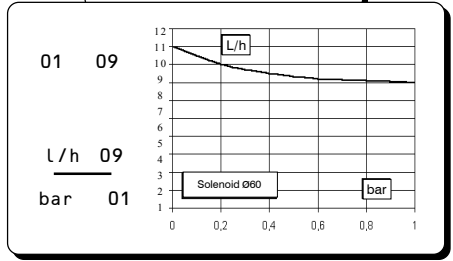

Pump Head PCS

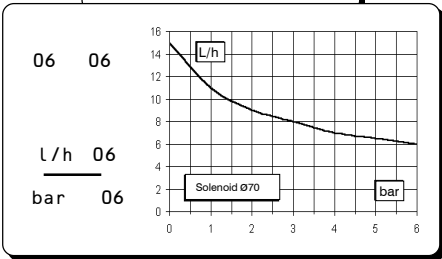

Pump Head 32

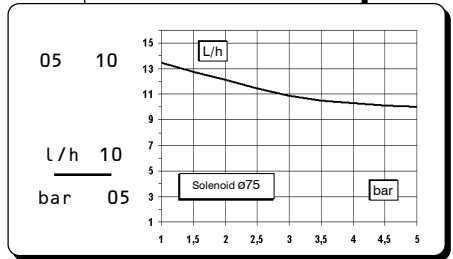

Pump Head PCS

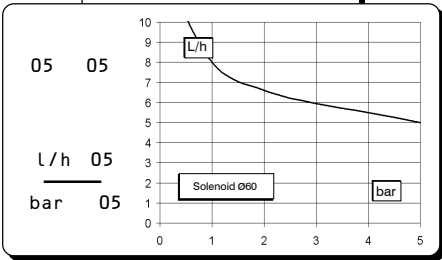

Pump Head PCS

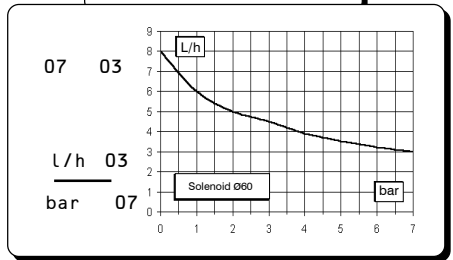

Pump Head PCS

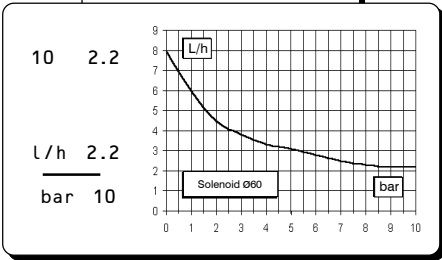

Pump Head PCS

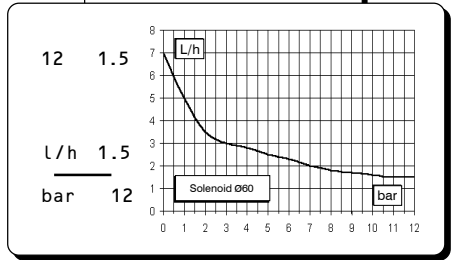

# Capacity charts

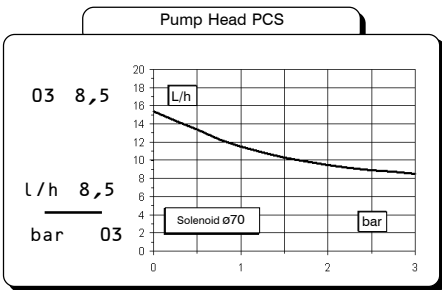
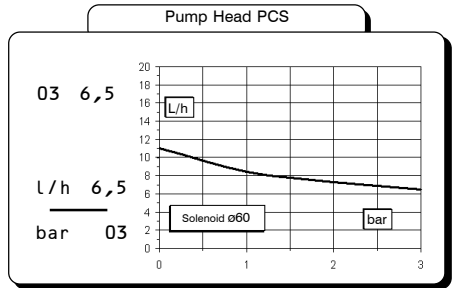
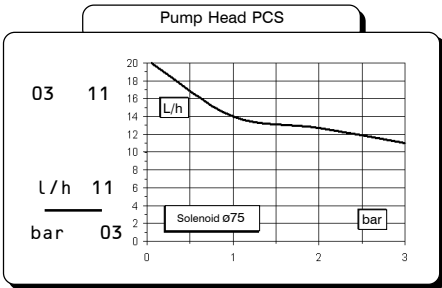
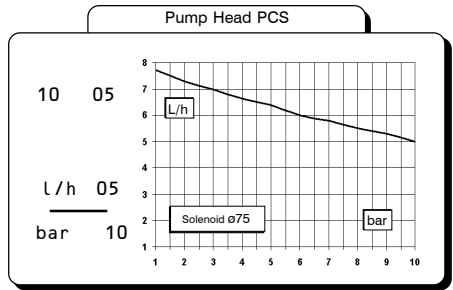
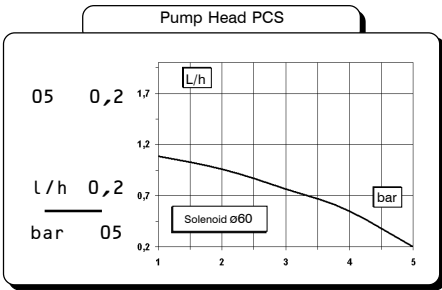
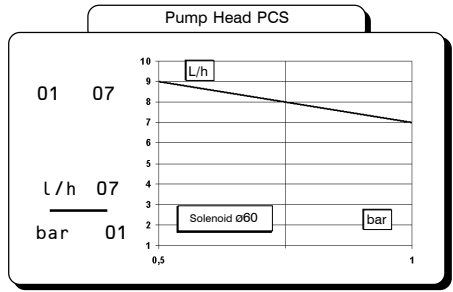
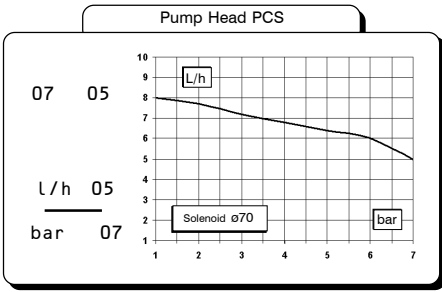

Flow rate indicated is for H<sub>2</sub>O at 20 °C at the rated pressure. Dosing accuracy ± 2% at constant pressure ± 0,5 bar.



## “F” and “FA” series pump installation drawings

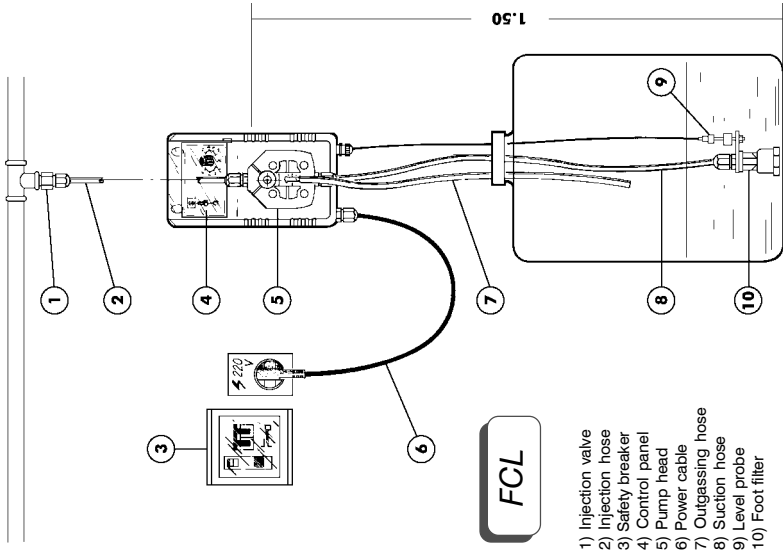

- 1) Injection valve
- 2) Injection hose
- 3) Safety breaker
- 4) Control panel
- 5) Pump head
- 6) Power cable
- 7) Outgassing hose
- 8) Suction hose
- 9) Level probe
- 10) Foot filter

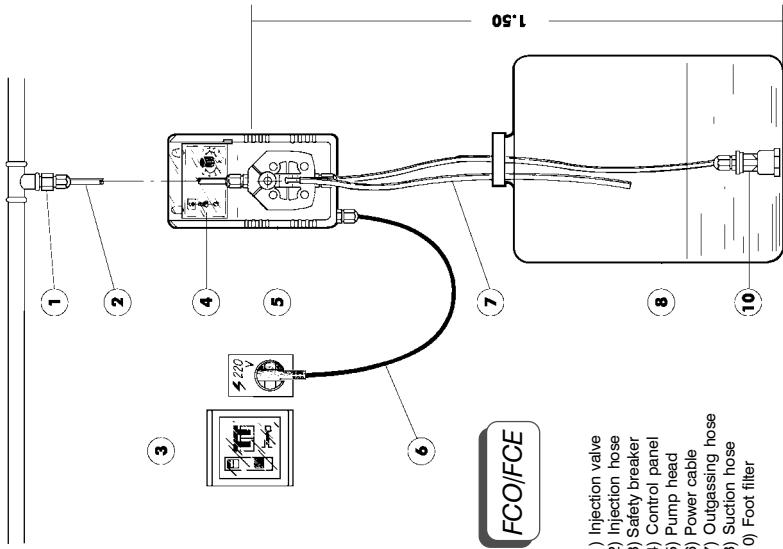

- 1) Injection valve
- 2) Injection hose
- 3) Safety breaker
- 4) Control panel
- 5) Pump head
- 6) Power cable
- 7) Outgassing hose
- 8) Suction hose
- 10) Foot filter

# "F" and "FA" series pump installation drawings

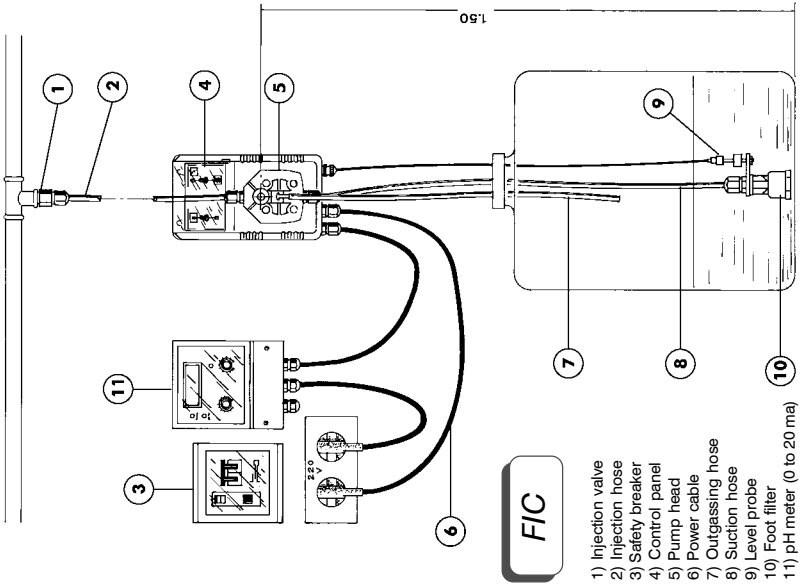

**FIS**

- 1) Injection valve
- 2) Injection hose
- 3) Safety breaker
- 4) Control panel
- 5) Pump head
- 6) Power cable
- 7) Outgassing hose
- 8) Suction hose
- 9) Level probe
- 10) Foot filter
- 11) pH meter (0 to 20 ma)

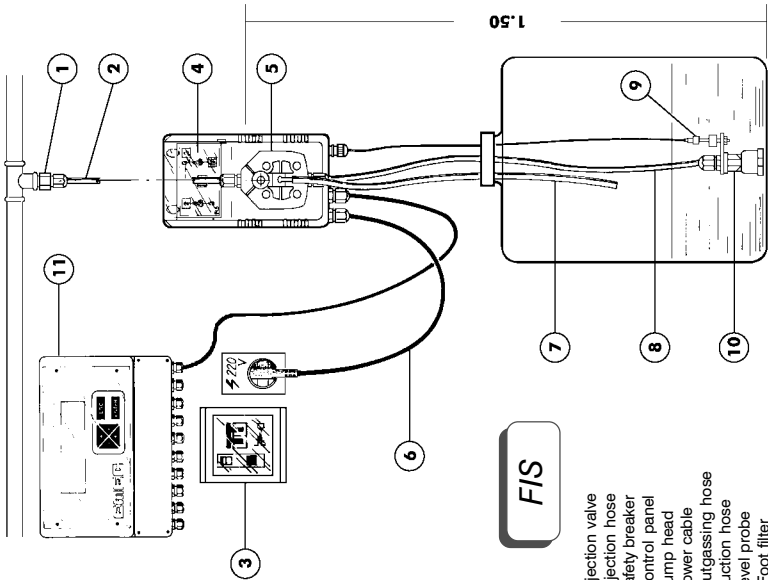

**FIS**

- 1) Injection valve
- 2) Injection hose
- 3) Safety breaker
- 4) Control panel
- 5) Pump head
- 6) Power cable
- 7) Outgassing hose
- 8) Suction hose
- 9) Level probe
- 10) Foot filter
- 11) Computer / CCS instrument

# "F" and "FA" series pump installation drawings

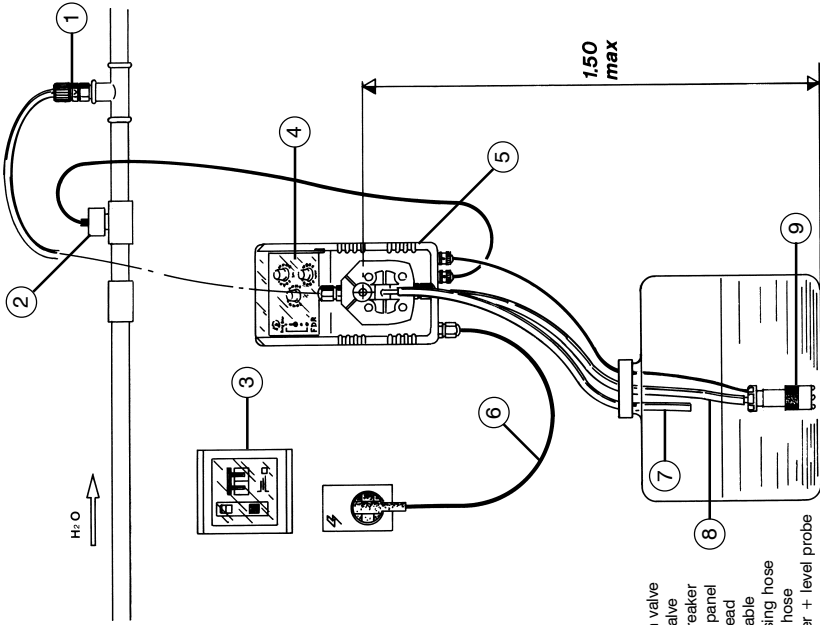

- 1) Injection valve
- 2) Electrovalve
- 3) Safety breaker
- 4) Control panel
- 5) Pump head
- 6) Power cable
- 7) Outgassing hose
- 8) Suction hose
- 9) Foot filter + level probe

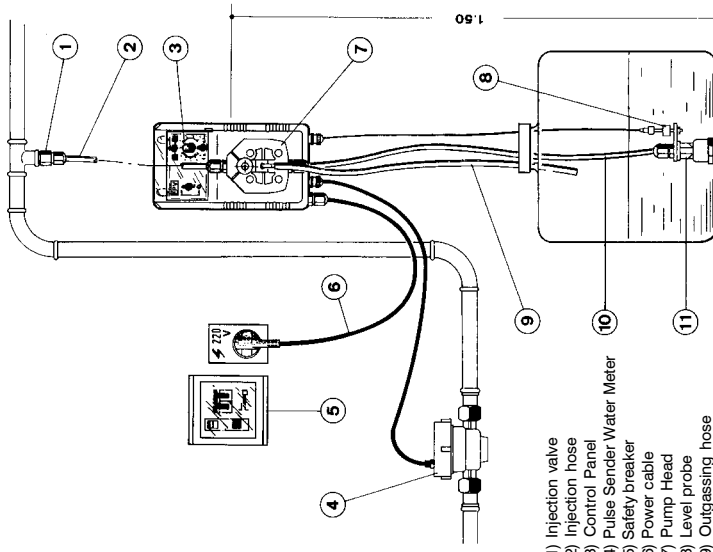

- 1) Injection valve
- 2) Injection hose
- 3) Control Panel
- 4) Pulse Sender Water Meter
- 5) Safety breaker
- 6) Power cable
- 7) Pump Head
- 8) Level probe
- 9) Outgassing hose
- 10) Suction hose
- 11) Foot filter

“F” and “FA” series pump exploded view

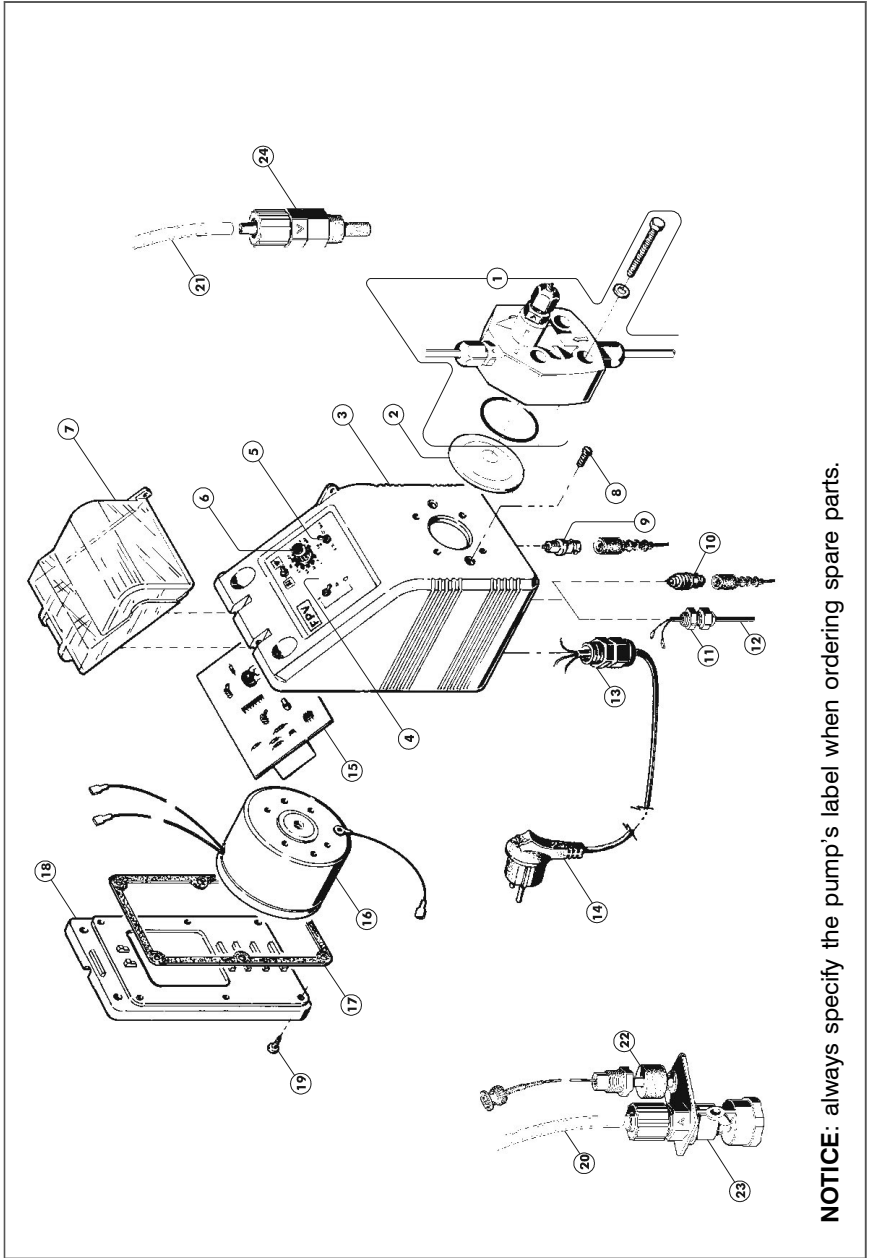

**NOTICE:** always specify the pump's label when ordering spare parts.

# "F" Series Commands Description

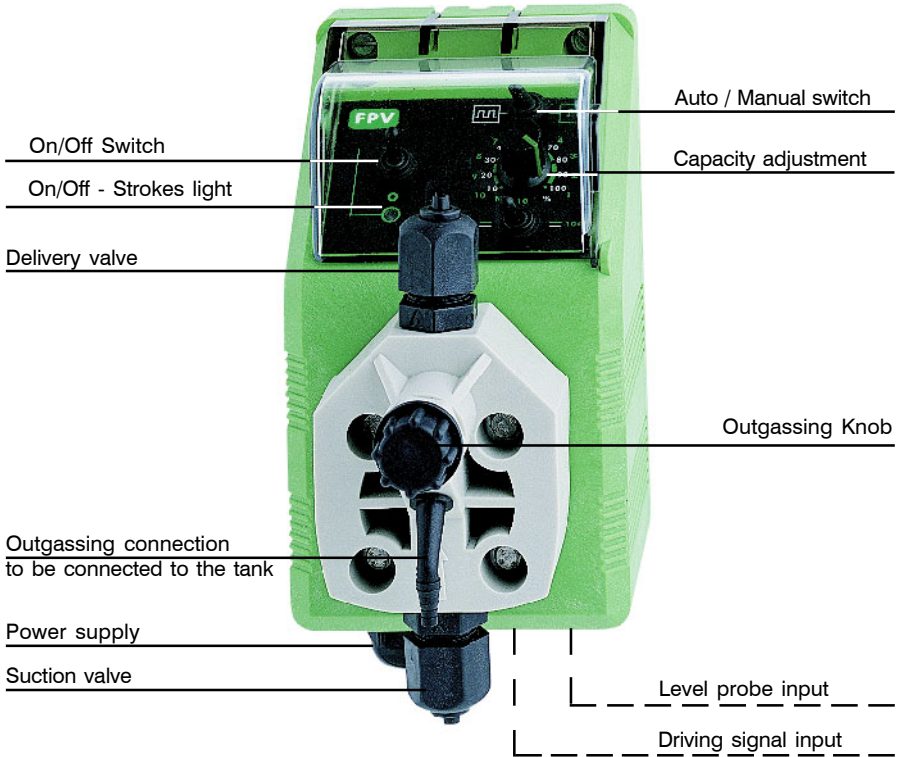

# "FA" Series Commands Description

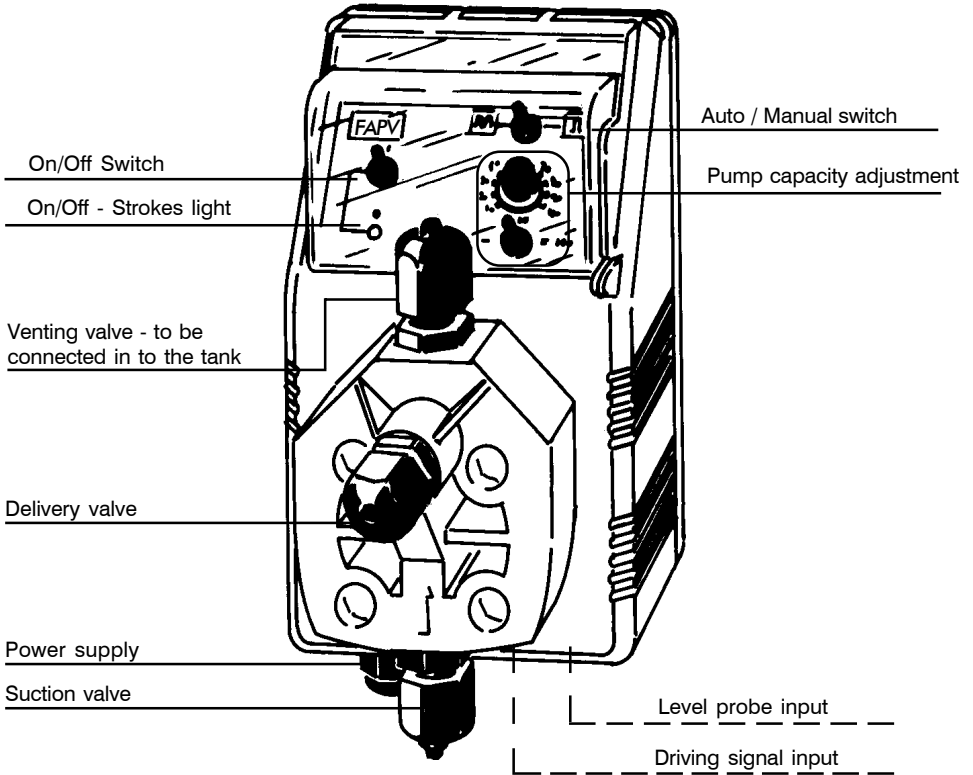

## Dimensions

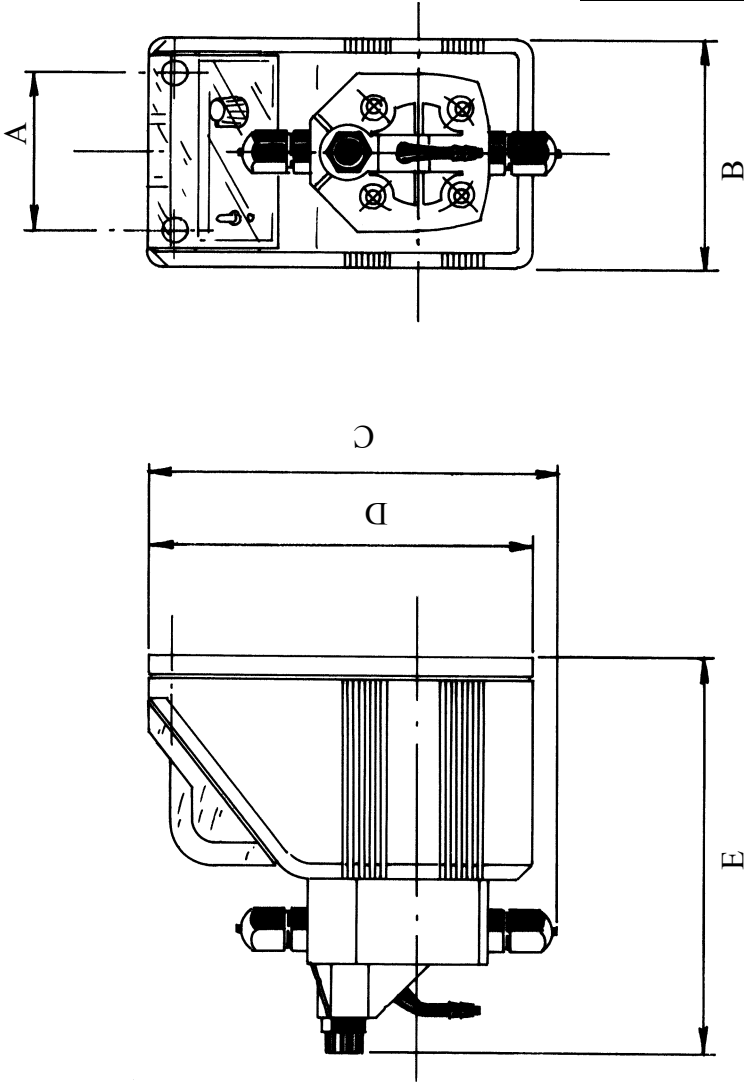

DIMENSIONS		
	mm	inches
A	63	2,48
B	91,5	3,60
C	168	6,61
D	153,5	6,04
E	160	6,29

<b>Recommended Chemicals Table</b>		
<i>Chemical Product</i>	<i>Formula</i>	<i>Maximum % Concentration</i>
Hydrochloric Acid	<b>HCl</b>	33%
Sulphuric Acid	<b>H<sub>2</sub>SO<sub>4</sub></b>	96%
Sodium Bisulphate	<b>NaHSO<sub>4</sub></b>	37%
Sodium Chlorite	<b>Na ClO<sub>2</sub></b>	30%
Sodium Hypochlorite	<b>Na OCl</b>	13,5%
Calcium Hypochlorite	<b>Ca (ClO)<sub>2</sub></b>	2%
Dichloroisocyanuric Sodium	<b>(CON)<sub>3</sub> Cl Na</b>	4%
Alluminium Sulphate	<b>Al<sub>2</sub> (SO<sub>4</sub>)<sub>3</sub></b>	18%
Ferric Chloride	<b>Fe Cl<sub>3</sub></b>	40%

NSF Listed units must be used with Sodium Hypo Chlorite.



## Auto-venting pump head

This pump head removes the gas from gaseous chemicals during operation, independently of back pressure.

**Attention: valves cannot be changed from their original position.**

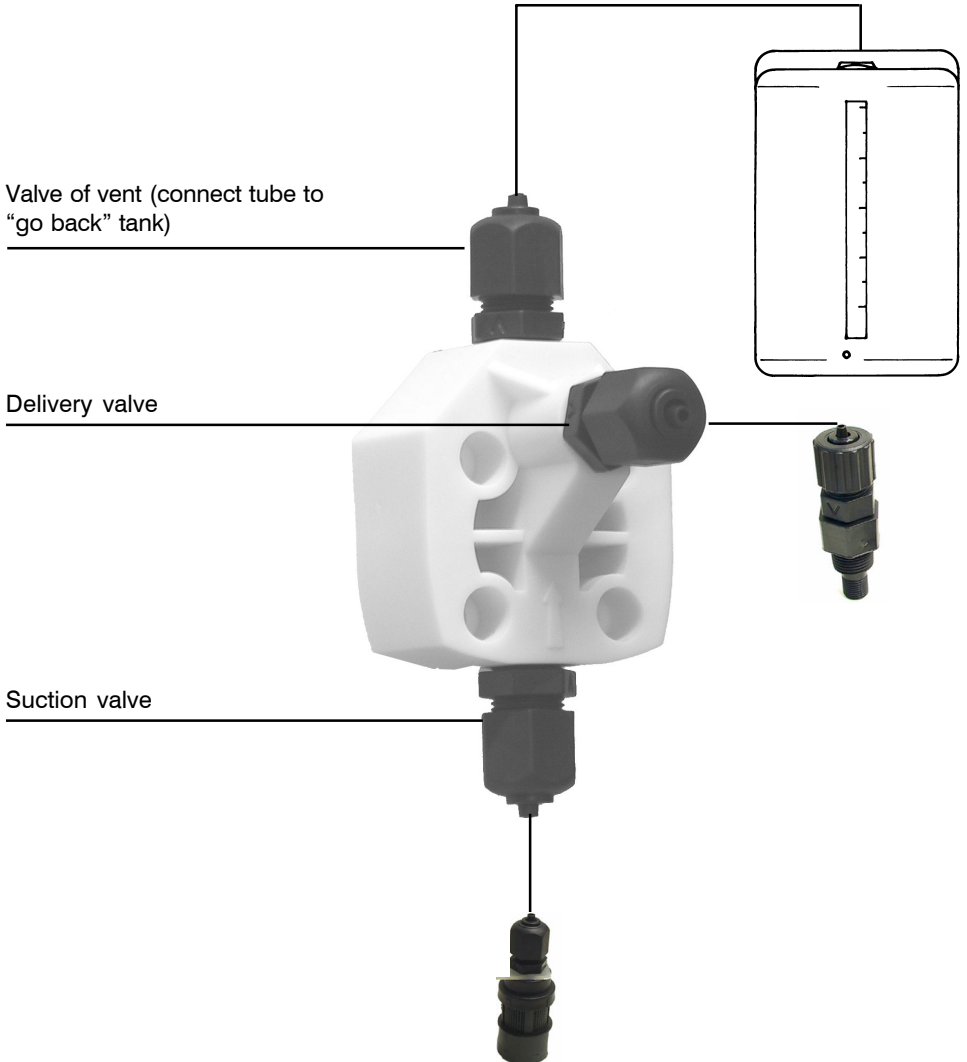





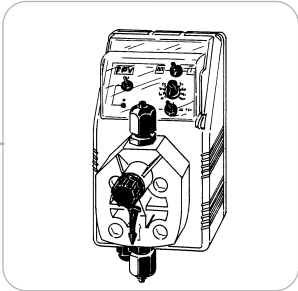

*When dismantling a pump please separate material types and send them according to local recycling disposal requirements.  
We appreciate your efforts in supporting your local Recycle Environmental Program.  
Working together we'll form an active union to assure the world's invaluable resources are conserved.*