

Operation, maintenance and installation manual

PLUNGER METERING PUMPS

While thanking you for your preference, we wish to give you hereunder some information for the correct installation and use of your **ATA** metering pump.

Read the instructions carefully before installing and starting the equipment; **ATA** will accept no liability for damages due to the non-observance of the content of this manual.

The information contained in this manual is subject to change without notice and does not represent a commitment on the part of **ATA**

INDEX

1. DESCRIPTION

- 1.1 Applications
- 1.2 Identification label
- 1.3 Mechanism
 - 1.3.1 Adjustment of the stroke length
- 1.4 Pumphead
 - 1.4.1 Operating principle
 - 1.4.2 Packing
 - 1.4.3 Packing adjustment
 - 1.4.4 Flushing

2. INSTALLATION

- 2.1 Safety precautions
- 2.2 General
- 2.3 Suction line
- 2.4 Discharge line

3. START-UP

4. MAINTENANCE

- 4.1 Precaution
- 4.2 Mechanism
- 4.3 Pumphead

4.4 Recommended spares

5. TROUBLE SHOOTING

6. HANDLING AND STORAGE

- 6.1 Handling
- 6.2 Storage and preservation

Installation suggestions table



MADE IN ITALY

1. DESCRIPTION

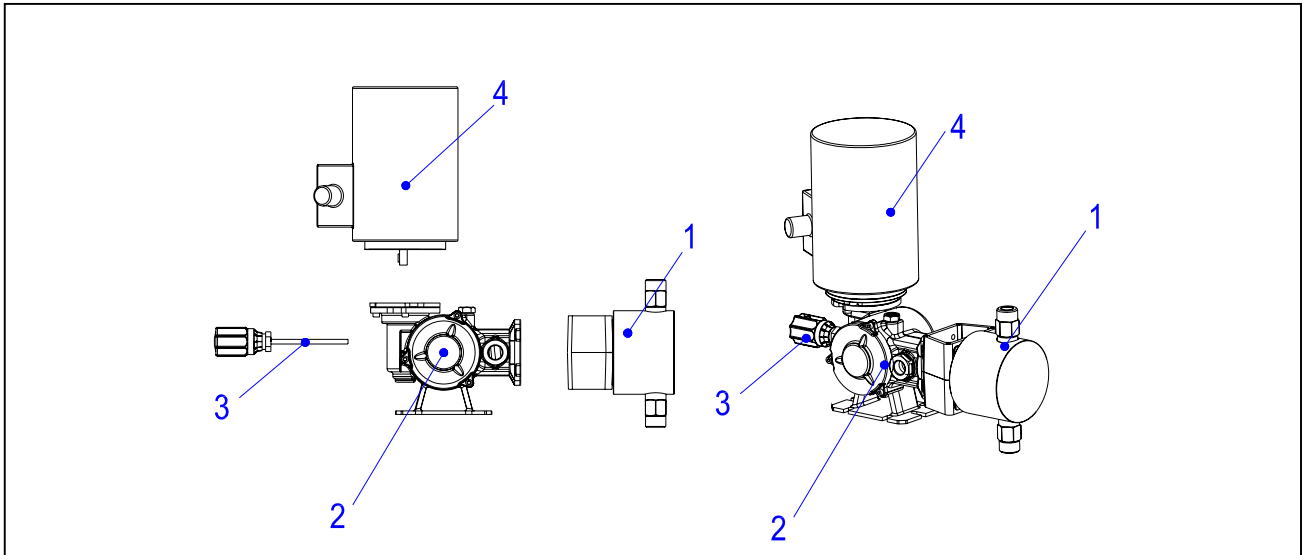

1	Testata	Cabeza	Pump head	Tête	Pumpenkopf
2	Meccanismo	Mecanismo	Mechanism	Mecanisme	Triebwerk
3	Regolazione	Regulaciòn	Adjustment	Régulation	Hubeinstellung
4	Motore	Motor	Motor	Moteur	Motor

The metering pump is a reciprocating positive displacement pump; basic components are: the prime mover (generally it is an electric motor), the gearbox, the mechanism, the stroke length adjustment and the liquid end .

⇒ **The design of the metering pump fulfills Italian safety and accident prevention regulations.**

Safety instructions



WARNING

Exceeding the maximum allowed operating pressure must be prevented

(e.g. by using a pressure relief valve)

Before starting to work on the metering pump verify carefully the following:

- the drive is disconnected from the power source
- parts such as pumphead and piping are depressurized
- parts in contact with aggressive substances are washed before handling
- personnel protection is carried out according to local regulations

1.1 Applications

Metering pump is a process component capable to transfer defined volumes of liquid with high accuracy, moreover it is possible to vary the flow rate by acting on integral devices.

To obtain the bestperformances, select the pump considering the duty required and the compatability of the construction materials of the contact parts.

Before using a pump for a duty different from the original one, please contact our Technical Dept. for information.

1.2 Identification label

Standard Actual dimensions: mm 65x35

MOD.	<input type="text" value="1"/>
<input type="text"/>	N.F. <input type="text" value="2"/>
L/h <input type="text" value="3"/>	bar <input type="text" value="4"/>
C E	<input type="text" value="5"/>
ATA	

1	Modello	Modelo	Model	Modèle	Modell Triebwerks
2	Numero di fabbrica	Número de matrícula	Serial Number	Numéro de fabrication	Baunummer
3	Portata	Caudal	Flow rate	Débit	Förderleistung
4	Pressione massima	Presión máxima	Maximum pressure	Maximum pressure	Maximaler Druck
5	Riferimenti	Referencias	Reference	Références	Bezugdaten

1.3 Mechanism and gearbox

Mechanism is the device that permits to transform the electric motor rotary movement in alternate and to actuate the plunger.

1.3.1 Adjustment of the stroke length

To obtain high accuracy performances pump must operate at ideal conditions: constant speed, pressure, viscosity.

Before turning the adjustment knob, release the adjustment by rotating of 1/4 of turn the lock screw.

TAP 15 – TAP 25

The variation from 0 to 100% of the maximum flow rate is obtained by rotating the adjustment knob counter clockwise; each revolution of the adjustment knob corresponds to a variation of 1/10 of the maximum capacity; moreover the knob edge is subdivided in 10 parts eachone corresponding to a variation of 1/100 of the maximum flow rate

1.4 Pump head

1.4.1 Operating principle

The packing (5) on the piston (4) seals the pumphead Suction (1) and discharge (2) valves are operated by positive and negative pressure

Suction (1) and discharge (2) valves are operated by positive and negative pressure

Suction stroke :

During the suction stroke the difference between the suction pressure and the pressure inside the process head (3) causes the opening of the suction valve (1).

The process liquid is sucked from the suction line into the process chamber (3).

Discharge stroke:

During the discharge stroke the suction valve (1) is closed and the discharge valve (2) will open due to the positive pressure inside the process chamber (3). The process liquid is discharged from the process chamber (3) into the discharge line.

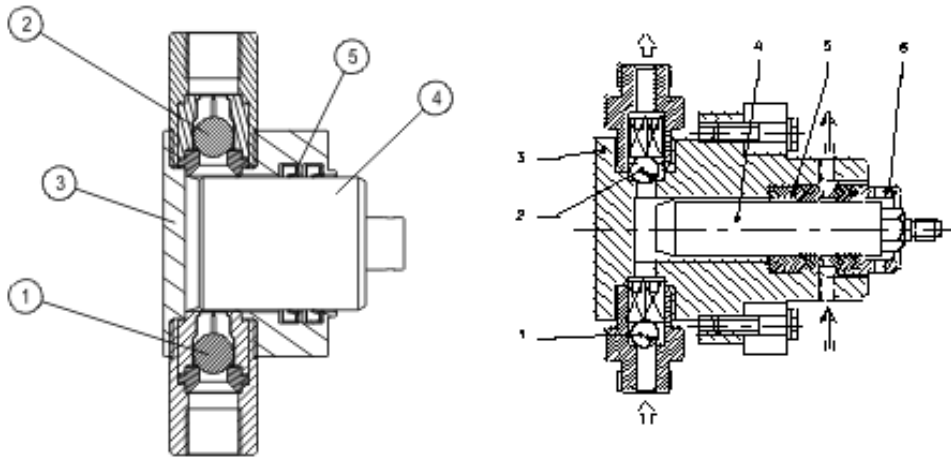

A	Tenuta con anelli a labbro	Junta con anillos de reborde	Lip seals packing	Etanchéité anneaux à lèvre	Lippenringen Dichtung
B	Tenuta con anelli a "V"	Junta con anillos en "V"	"V" seals packing	Etanchéité anneaux à "V"	"V" Ringen Dichtung
1	Valvola di aspirazione	Válvula de aspiración	Suction valve	Vanne d'aspiration	Ansaugventil
2	Valvola di scarico	Válvula de impulsión	Discharge valve	Vanne de refoulement	Auslaßventil
3	Testata	Cabeza	Pump head	Tête	Prozeßkammer
4	Pistone	Pistón	Plunger	Piston	Kolben
6	Tenuta	Junta	Packing	Garniture	Kolbendichtung

1.4.2 Packing

Plunger pumps can be equipped with different types of packing:

Self-adjusting, pag. 5 fig. A

It consists of lip seals that don't require any adjustment

"V" seals , pag. 5 fig. B

It consists of seals having a "V" section, they are designed in such a way that their lips adhere, due to the pressure, to the plunger and head internal surfaces during the discharge stroke.

1.4.3 Packing adjustment

It is a periodic operation required with "V" or **square section** packings only. Should excessive leakage occur, compress slightly and gradually the packing by screwing the ring nut (fig. B/C pos. 5) or packing gland screws; this operation must be done with the pump stopped.

With spring return pumps don't compress too much the packing to avoid that the anomalous friction hinders the plunger return.

Avoid always the excessive compression of the packing that will cause the quick wear of the packing.

The liquid leakage of some drops per minute must be tolerated in order to cool and lubricate the plunger, prolonging the packing life.

Should the leakage continue after the packing adjustment, it could be necessary the replacement of the packing (see paragraph 4.3)

1.4.4 Flushing

The pumphead could be equipped, on request, with two threaded holes (see fig. B/C pos. 7) generally used to connect pipes for flushing that can be done with water or other suitable detergent.

Flushing is required to prevent the formation of scales or deposits, to dilute and eliminate leakages; it is advisable to use flushing when pumping liquids such as lime, soda, phosphate etc. that tend to crystallize if exposed to the atmosphere.

When required, connect the flushing lower hole to the water supply and adjust the water flow rate at few drops per minute, connect the flushing upper hole to a hose that can be used to collect leakages in a suitable drain.

2. INSTALLATION

2.1 Safety precautions

To minimize accident risk during the installation follow the instruction contained in the paragraph 6.1 and in addition:

- don't work alone
- install a magnetic starter with overload protection
- connect motor to grounding
- when working on the pump verify that electric motor or servomotor are not connected to mains.
- using electric tools in hazardous areas, pay attention to special regulations
- keep available a first aid kit
- observe local law safety regulations

Installation

- Foundation height should be so as to facilitate maintenance operation, handling, oil refill and drain, easy disassembling of pumphead
- Install the pump **free of strain** on its base, pumphead connections and foundation
- Install the pump levelling the piston axis horizontally and the valve axis vertically

Electrical connection

DANGER

**Electric motors and electrical components should be connected in accordance with local regulations and by qualified personnel only.
Install overload protection or temperature sensor.
Check voltage, frequency, motor speed and power.
In hazardous areas special regulations must be applied.**

2.2 General

For a good operation, the correct installation of the pump is fundamental:

- Before carrying out hydraulic connections, make sure that the inside of pipes, tanks, etc. have been thoroughly cleaned/washed. However we recommend the installation of a temporary filter near to suction nozzle in order to stop plant residues and slags.
- Connect pipes avoiding nozzles stretching
- Install pipes correctly sized for the maximum flow rate of the pump, avoid necks and tortuosity where air or gas could be entrapped.
- Check valves and cross fittings should be installed both in the suction and discharge lines, this will permit to disassemble the pump without draining the plant and/or to install accessories such as pressure gauges, dampners a.s.o.
- Install an expansion joint when pumping liquids having high temperature
- In case of plastic head, install flexible joints both on suction and discharge sides.
- **ATA** hydraulic diaphragm metering pumps can operate with an NPSH up to 70 Kpa abs. equal to 7 m.w.c. (NPSH = Net Positive Suction Head), however, in order to improve dosing accuracy and to accelerate priming, it is advisable to install pump with a slight positive head



WARNING

To prevent serious damages suction and discharge lines must be properly designed, sized and connected to the pump.

2.3 Suction line (see installation recommendations table, pag 14)

- Install pipe as short as possible (fig. 1) and avoid tortuous paths (fig. 2)
- Pipe should be sized considering that the ratio between the maximum instantaneous flow rate and the average flow rate is 3.14 for a simplex pump (Fig. D pag. 9), 1,5 for a duplex pump (having plungers out of phase of 180°), 1.05 for a triplex pump (having plungers out of phase of 120°).
- Indicatively the installed pipe should have a diameter equal to 1.5 the diameters of the pump nozzles.
- For your guidance the recommended flow speed inside the pipes should be 0,5÷0,8 m/sec with liquids having viscosity near water and specific gravity up 1200 Kg/m³.
- A permanent suction filter must be installed . The filter should have a filtering cartridge of 150 µm giving a pressure drop less than 0.2 m.w.c. (calculated according to the a.m. coefficients). The filter should be easily accessible and periodically checked and washed.
- In case of long lines and in order to avoid cavitation problems, install, near the pump, an expansion tank or a damper (fig. 3).
- To prevent suction of impurities don't connect suction line to the bottom of the tank (fig. 4)
- Suction from a vacuum tank can be achieved by connecting pipes as per fig. 5. open check valve 2 and verify the filling through the the window 3, close the check valve 2, start the pump; the non-return valve 4 prevents liquid to flow-back when pump is stopped.

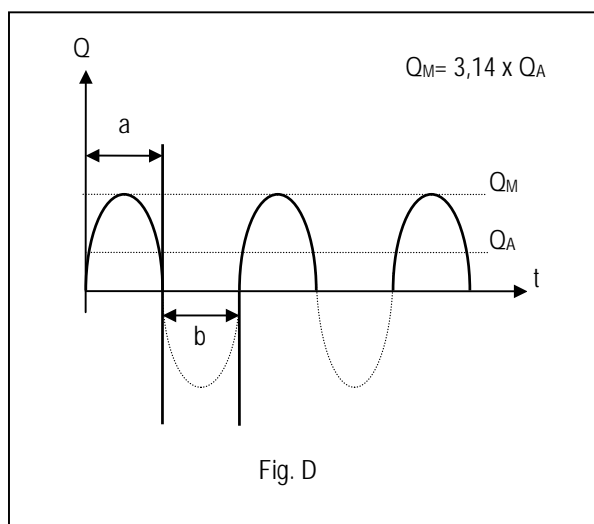

Q	Portata	Caudal	Flow rate	Débit	Förderleistung
Q _A	Portata media	Caudal promedio	Medium Flow rate	Débit moyen	Durchschnittliche
Q _M	Portatamassima	Caudal máximo	Maximum flow rate	Débit maximale	Max. Durchflus- smenge
a	Corsa di scarico	Carrera de impulsión	Discharge stroke	Course de refoulement	Auslaßhub
b	Corsa di aspirazione	Carrera de aspiración	Suction stroke	Course d'aspiration	Ansaughub
t	Tempo	Tiempo	Time	Temps	Zeit

2.4 Discharge line (see installation recommendations table, pag. 17)

- Verify that between suction and discharge there is a positive pressure of at least 50÷ 100 Kpa; if the plant conditions don't permit a positive pressure difference, install a back pressure valve on pump discharge (fig. 6) or lower suction tank (fig. 7) or raise discharge pipe (fig. 8)
- For safety reasons it is mandatory to install a pressure relief valve in order to prevent dangers as consequence of unexpected overpressure; the pressure relief valve discharge should be visible and/or piped back to the tank or to a drain.
We do not recommend to pipe the pressure relief valve discharge to the pump suction line (fig. 9).
- In case a back pressure valve is installed the pressure relief valve must be installed as shown in fig. 10.
- It is recommended the installation of pressure gauges having a range of 20% higher than the pressure relief valve setting.
- To reduce flow pulsation, the installation of a pulsation damper near the discharge valve of the pump is highly recommended.

The most used dampers are:

- dampers with direct contact between process liquid and gas/air cushion (air chamber); this type is of simple concept but it needs frequent checks and restoring of the atmospheric air cushion.
- dampers with diaphragm or bag which separates gas/air from process liquid; they are generally precharged at a pressure equal to 60÷75% of the maximum operating pressure of the pump when installed on the discharge side of the pump.

These dampers require periodic checks to verify diaphragm/bag integrity and correct precharge pressure; they must be selected considering the chemical compatibility of the construction material of diaphragm/bag.

If a back pressure valve is installed, the damper should be installed as shown in Fig. 11.

A) in case of low pressure; for a correct operation the precharge pressure of the damper should be higher than the back pressure valve setting

B) in case of high pressure

Should you need more information relevant to the selection/installation of the pulsation damper, please contact our Technical Dept.

If the pump discharges into a pressurized line, the installation of a non-return valve is recommended.

- ⇒ When installing pump and accessories it is recommended the installation of check valves in order to facilitate maintenance operations. Fig. 13 shows a typical installation.
- ⇒ Please observe the following instructions when pumping liquids that tend to crystallize or suspensions that tend to sediment:
 - keep suspension correctly agitated in order to prevent sedimentation
 - avoid installation of vertical lines over the pump discharge nozzle
 - before stopping the pump start a washing cycle of the pump and pipes
 - design suction and discharge lines should permit complete emptying

3. START-UP

Electrical connection:

- connect electric motor to mains (power source)
- check the direction of rotation of the electric motor; an arrow on the electric motor shows the correct direction of rotation

The electric motor should be connected by qualified personnel only!

WARNING

**Don't start the pump with the suction and/or discharge check valves closed
Don't close check valves while the pump is in operation**

Before starting the pump check the following points:

- check mechanism for the correct oil filling
- check pumphead for the correct filling of the hydraulic liquid
- check metering pump for overpressure protection (pressure relief valve installation)
- verify that all hydraulic connections are correctly tight
- position adjustment knob at "zero" flow rate (see para 1.3.1)
- start the pump without discharge pressure and increase progressively the flow rate up to 100%
- check the hydraulic chamber for possible air bubbles intrapped in the liquid pushing the replenishing valve until no air is blown out
- keep the pump in operation for few minutes
- increase progressively the pressure until the required performances are reached



WARNING

DON'T EXCEED THE MAXIMUM PERFORMANCE STENCILLED ON THE PUMP LABEL

If no pressure gauge is fitted on the plant, the installation of a temporary pressure gauge is recommended in order to check that the actual pressure at the start-up doesn't exceed the maximum allowable pressure.

- ⇒ **ATA** pumps are self-priming, however some priming problem could be encountered with pumps having very low flow rate, small plunger diameter, with back pressure valves installed and in presence of high discharge pressure. In these cases it could be necessary to aid priming purging air from pumphead and suction line.

WARNING

If the pumped liquid is toxic, poisonous, aggressive, flammable or for any reason dangerous, use particular care avoiding accidental leakages through gaskets or pipes during start-up or maintenance operations.

Moreover follow all the recommendations of the manufacturer for handling and the local laws relevant to safety during handling and disposal of dangerous substances.

4. MAINTENANCE

4.1 Precautions

- Before servicing pump or plant verify that all electric connections (power and control) have been disconnected from mains and are no more fed.
- Depressurize completely pump and pipes and drain the section in which maintenance is required
- Always work wearing the required safety protections.
- Don't pour in the ambient polluting substances such as pumped chemicals, hydraulic liquid, lubricating oil a.s.o.
- Before servicing pump or plant read carefully the technical specification of the handled fluids with particular respect to the actions that must be done in case of accidental contact with a dangerous fluid.

4.2 Mechanism

Pumps are generally supplied complete with the first oil filling; replace oil after 1500 operation hours and afterwards every 4000 hour.

However replace oil every year .

Use the recommended oils listed here below or equivalent.

Check weekly the oil level and, when required, restore the correct level using the same oil; check also for possible leakages through the lip seal on the piston rod and if necessary replace the lip seal.

MOD.	Lt.	AGIP	BP	ESSO	IP	MOBIL	SHELL	T °C
Tap 15	0.3	BLASIA 150	ENERGOL GR-XP150	SPARTAN EP 150	MELLANA OIL 150	MOBIL GEAR 629	OMALA OIL 150	
Tap 25	0.4	BLASIA 150	ENERGOL GR-XP150	SPARTAN EP 150	MELLANA OIL 150	MOBIL GEAR 629	OMALA OIL 150	

4.3 Pumphead

Don't let the pump running without process liquid.

As minimum every six months, dismount the pumphead as follows:

- Disconnect suction and discharge pipes
- Drain process liquid from pump head and pipes
- unscrew bolts fixing the pumphead to mechanism
- dismount suction and discharge valves

and carry out the following operations:

- wash thoroughly the suction and discharge valves and verify whether any part is worn or scratched; replace them if required
- replace plunger packing in case it is worn; grease new seals before assembling
- check the plunger sliding surface where seals operate; the surface should be without scoring or scratches; when damaged replace the plunger

4.4 Recommended spares

In order to face normal service problems and to avoid possible waste of time, we suggest to keep in stock a small supply of the following spares:

- One plunger
- Two sets of plunger packing
- One suction valve complete
- One discharge valve complete
- One set of mechanism seals

When ordering spares, please indicate always the model and the serial number of the pump

5. TROUBLESHOOTING		
Trouble	Possible cause	Remedy
Flow rate too low or no flow rate	Suction tank sealed without vent	Install vent or open tank cover
	Suction of air through fittings, gaskets, etc.	Tighten connections
	Air/gas pockets into the pump or in the pipes	Facilitate air exit
	Suction filter or suction line clogged	Wash filter and/or remove occlusion
	Check valves closed	Open valves
	Excessive suction head	Reposition pump at the correct elevation
	Vapour pressure too high, liquid temperature too high	Cool liquid
	Viscosity too high, liquid temperature too low	Heat liquid
	Pump valves dirty or worn	Wash valves or replace them
	Strokes per minute less than rated	Check speed and electrical feeding
	Suction pipe diameter too reduced	Check suction line for length and diameter
	Pressure relief valve set at a value lower than the maximum discharge pressure	Check pressure relief valve setting and actual operating pressure
	Wrong stroke length	Check stroke length and adjust if required
	Excessive leakage through packing	Tighten packing, check plunger and packing for wear; replace worn parts
Pressure relief valve in operation or leaking	Check for correct setting and/or clean pressure relief valve	
Flow rate too high	Discharge pressure lower than suction pressure	Install a back pressure valve
	Wrong stroke length	Check stroke length and adjust if required
	Back pressure valve faulty or setting pressure inadequate	Reset back pressure valve or replace it
	Strokes per minute more than nominal	Verify electrical feeding
Electric motor overheating	Discharge pressure too high	Check pressure relief valve setting
	Discharge line incorrectly sized	Check discharge line length and diameter
	Wrong electrical connections	Check and rectify connections
Noisy operation	Lack of lubricant in the mechanism/gearbox	Refill with the correct lubricant
	Excessive wear of the mechanism/gearbox	Overhaul mechanism/gearbox
Pipes vibrations	Pipe diameter too small	Enlarge pipe diameter
	Pulsation damper out of operation or too small	Repair or recalculate damper volume

6. HANDLING AND TRANSPORTATION

6.1 Handling

The correct way to handle the pump is shown on the drawing here below.
If the pump is assembled on a baseplate with lifting lugs use them for handling.

⇒ **in any case note the following instructions:**

- **do not sling, pull, push** the pumphead nozzles or flanges
- **do not sling, pull, push** the pressure relief valve bowl
- **do not sling, pull, push** the adjustment knob
- **do not sling, pull, push** the plunger

⇒ **when lifting loads pay attention to the following**

- dress helmet, accident protective shoes and gloves
- do not stand under hanging loads
- do not hand lift overload
- when hand lifting load do not assume position that can be dangerous for the spinal column and dorsal muscles

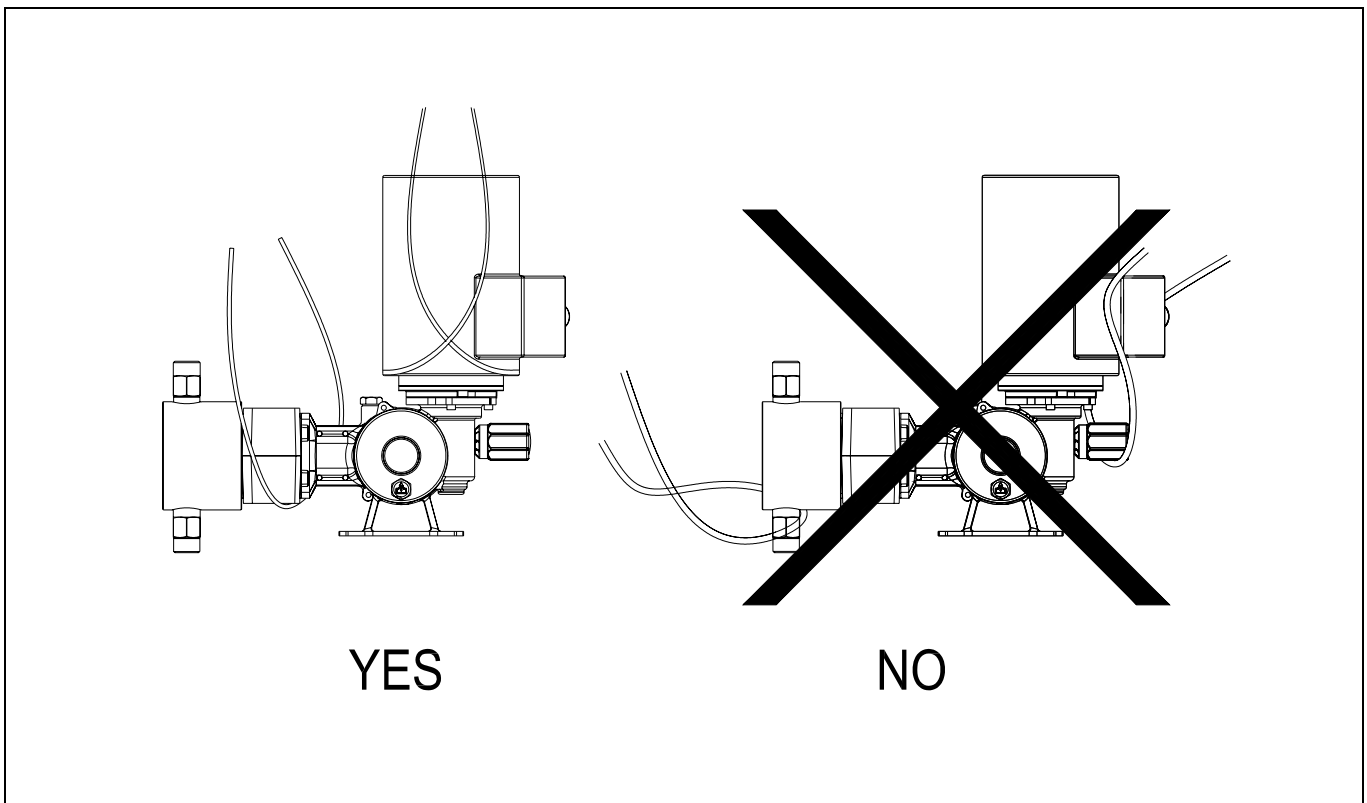

6.2 Storage and preservation

ATA pumps are delivered completely filled in with lubricant oil into the mechanism and with the hydraulic fluid into the pumphead.



WARNING

During transportation and during storage pump must be protected against moisture, salt water, rain, sand storm and direct sunlighth.

Should the pump be stored for a long time, proceed according to following instructions:

A. Storage in a dry and ventilated place

Pump can be stored for a period of one year without taking any special precaution

B. Storage in places with high humidity

Pump must be hermetically sealed and protected against perspiration using an adequate quantity of silica gel; then storage for one year is possible.

C. Storage outdoor

In addition to recommendation of point B, additional protection against rain, sand, dust, dirty and direct sunlight are required.

D. Precaution after installation of a pump

Before start-up check that mechanism and hydraulic chamber are correctly filled in.

If the put in operation is delayed, the metering pump should be started for one hour approx. every month with the stroke length at "zero", see paragraph 1.3.1.

However the lubricant oil of the mechanism must be changed every year.

Replace again the lubricant oil in the mechanism before the actual start in operation.

Should the pump be out of operation for a long period after installation, the additional following precautions must be taken:

- disassemble pumphead completely and wash all parts carefully
- disassemble, clean and grease the packing; reassemble it without tightening the packing gland
- grease all machined parts
- pour protective lubricant into the movement and gearbox; operate the pump for some minute
- when restarting, drain protective lubricant and refill with suitable lubricant
- keep the pump in a dry place and adequately protected from dust

Installation suggestions table

		SERBATOIO TANK TANK	DEPÓSITO RESERVOIR
		POMPA DOSATRICE DOSING PUMP DOSIERPUMPE	BOMBA DOSIFICADORA POMPE DOSEUSE
		POMPA AUSILIARIA BOOSTER PUMP HILFSPUMPE	BOMBA AUXILIARA POMPE AUXILIAIRE
		PULSION DAMPER PULSIONDÄMPFER	DEPÓSITO DE COMPENSA- CIÓN POUMON AMORTISSEUR
		SERBATOIO IN PRESSIO- NE PRESSURIZED TANK TANK UNTER DRUCK	DEPÓSITO EN PRESIÓN RESERVOIR PRESSUR
		FILTRO A "Y" "Y" FILTER "Y" FILTER	FILTRO A "y" FILTRE A "Y"
		SPIA WINDOW SCHAULGLAS	MIRILLA TEMOIN
		VALVOLA DI CONTRO- PRESSIONE CHECK VALVE GEGENDRUCKVENTIL	VÁLVULA DE CONTRA- PRESIÓN VANNE DE CONTRE- PRESSION
		VALVOLA DI SICUREZZA PRESS RELIEF VALVE SICHERHEITSVENTIL	VÁLVULA DE SEGURIDAD VANNE DE SECURITE
		VALVOLA A GALLEG- GANTE FLOAT-OPERATED VALVE SCHWIMMERVERTIL	VÁLVULA FLOTANTE VANNE A FLOTTEUR
		MANOMETRO PRESSURE GAUGE MANOMETER	MANÓMETRO MANOMETRE